

LDN Series



BSB

A brand of
MAICO

V12204

Installation, Operation and Maintenance Instructions

MANUFACTURERS OF AIR, FIRE AND SMOKE CONTROL PRODUCTS



THESE INSTALLATION INSTRUCTIONS MUST BE READ IN THEIR ENTIRETY BEFORE COMMENCING WORK TO ENSURE COMPLIANCE

Dampers will only be CE marked and have a valid warranty if:-

- Installed as tested
- No deviation to design
- These instructions are followed

Third party approval will be required for any non-tested proposal.

Before commencing installation, the "Installation Check List" within DW/145 should be referred to. (Page 8 - BSB personalised version).

Fitted actuators should not be demounted without first consulting with BSB Technical Support Team.

LDN (Lobby damper - Natural vent)

1. Application

- 1.1 The LDN damper is a key component of a Natural Smoke Ventilation System, providing both fire resistance when the damper is closed, and ventilation when open.
- 1.2 A minimum 1.5m² free area for a BRE shaft will be required as stated in ADB.
- 1.3 On receipt of a signal from the fire alarm system, the damper(s) on that level of the fire will open and the dampers on all other levels close, thus preventing the spread of smoke and fire from the riser shaft on those levels. This offers a safe means of escape for occupants, providing a greater visibility and access for fire fighters.

2. Health and Safety

- 2.1 Only competent personnel may carry out the work outlined in this document. Current IET wiring regulations must be adhered to (refer to Important Safety Notice on page 1). Appropriate Personal Protective Equipment as required for safe working conditions and as site rules dictate must be used.

2. Health and Safety continued

- 2.2 Dampers may be heavy and care in moving and installing must be taken. Larger dampers will require suitable lifting and supporting equipment, with due consideration given for manual handling. Do not lift the damper via the blades, as this may impact on its operation.
- 2.3 Where dampers are only accessible with the need for additional elevation, any equipment used should be done so with due consideration to the Work at Height regulations 2005 and current site rules.
- 2.4 All work should be carried out in accordance with HSE guidelines and regulations and any specific local site rules.

3. Health and Safety continued



Important Safety Notice

- 3.1 It is the responsibility of the person installing the electrical equipment to ensure that the installation meets the requirements of the IET wiring regulations and is therefore 'fit for purpose'.
- 3.2 Factors such as correct selection of components, cable management, cable sizing, protective devices and earth bonding are all critical and should be checked prior to testing and power-up.
- 3.3 Any other regulations applicable to the equipment being installed such as the current health and safety legislation must also be adhered to. The equipment is a life safety product and should be inspected periodically as described in BS 9999. This includes visual inspection, electrical and function testing of the installed equipment.
- 3.4 Combination of power supply voltage and safety extra-low voltage not permitted at both auxiliary Switches.
- 3.5 Do not lift the damper via the blades, as this may impact on its operation.

4. Important

- 4.1 The installer must be competent with the manufacturers products and installation methods.
- 4.2 Actuators are IP54 rated - Check actuator connection box is suitably located.
- 4.3 All installations are subject to local Building Control Approval (BCA). Tested Installations are detailed herein. If the proposed installation has minor variations to that shown, acceptance from BCA should be sought before proceeding. Manufacturers are not permitted to approve any deviations from the tested installation method.
- 4.4 UPS Battery Back Up. EN12109-10 section 7.2 refers.
It should be noted that with the on/off actuator provided with the LDN damper, on loss of power will remain at the position when power was lost. The LDN damper should have two sources: primary and secondary as described in EN12101-10.

5. Equipment Required

- 5.1 Equipment and tools will vary dependent upon the fire barrier construction that the damper is being installed within. Standard equipment normally used for the building of the particular barrier should suffice.
- 5.2 Access-equipment as necessary.
- 5.3 Temporary support equipment (to retain damper in position).
- 5.4 Cordless drill, 7mm masonry drill bit and dry wall and masonry screw bit 6.5mm dia x 60mm.
- 5.5 Screwdriver to suitable connection box and terminals (short screwdriver may be required.)
- 5.6 Supplied 3mm a/f Allen key for grille installation.
- 5.7 Sealant gun and sealant. 6.5mm dia x 60mm.

6. Separation between fire dampers and between fire dampers and construction elements

- 6.1 In accordance with EN 1366-2: 2015.
- 6.2 A test result for only one fire damper or for two fire dampers with a minimum clear separation of 200mm is applicable to a minimum separation in practice of:
 - 6.2.1 200mm between fire damper cases installed in separate ducts.
 - 6.2.2 75mm between fire damper and a construction element (wall/floor)
- 6.3 e.g. for a damper in a wall, this is the distance between casings and not installation frames mounted in the supporting construction and a wall or floor adjacent to that supporting construction.

7. Dry Walls Typical Installation Procedure for Damper and Grille - Refer to Fig 1.

- 7.1 For installing into dry walls, the aperture must be "lined out" with track and one layer of plasterboard on all four sides. See Fig 1.
- 7.2 The aperture needs to be 10mm larger than the damper sleeve, providing 5mm installation clearance all round.
- 7.3 Before installing the damper into the wall, remove the actuator cover plate, and retain with fixings safely. Prepare all electrical connections including cable entry holes using the appropriate grommets. Actuator data and wiring connections are given on page 6.

- 7.4 Apply a 6 - 10mm bead of intumescent mastic to the inside of the perimeter sleeve return flange.
- 7.5 Position the damper centrally within the aperture with the actuator enclosure at the left hand side and horizontal blades behind. A gap of 5mm between the wall and the damper sleeve on all four sides should be confirmed. The use of a 5mm spacer at the bottom between the damper case and aperture would assist.
- 7.6 Using min. 3.5mm dia. x 38mm long drywall screws, fix the damper to the wall using all the pre-punched fixing holes in the sleeve ensuring screws 'pick-up' with the track lining the aperture so that the required fire integrity of the installation is not compromised. Once the screw head touches the damper sleeve, apply another ½ turn. DO NOT overtighten as this will distort the case stopping the grille from being fitted. When using an electric drill or impact drive, do so carefully as you may crease or deform the sleeve.

Once the damper has been installed, check that all the fixings are in place, and that the damper is correctly fitted into the aperture. Test and inspect the damper to ensure that the blades fully travel in both directions.

- 7.7 Check that all electrical connections are correctly made and tidy and that cable entry through the damper sleeve is sealed.

Refit the actuator cover ensuring all fixings are used.

Refit the grille using the screw fixings supplied starting with the middle fixings first followed by the outer fixings.

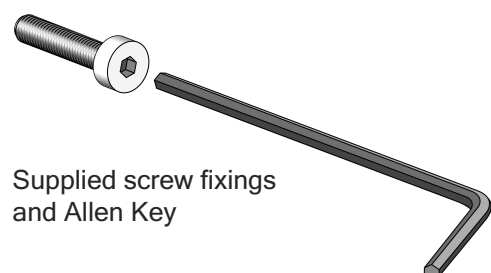
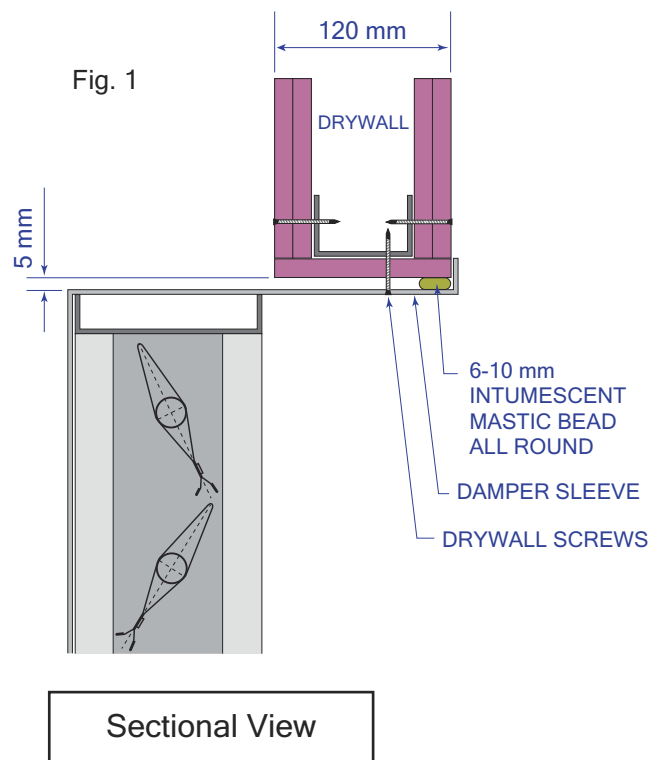

8. Masonry Walls Typical Installation Procedure for Damper and Grille Refer to Fig 2.

- 8.1 Form the aperture 10mm larger than the damper sleeve, providing 5mm installation clearance all round.
- 8.2 Mark the size required onto the wall in the required position with chalk. Using a circular saw with a concrete cutting blade, start halfway down one of your marked lines. Do not start from a corner as the cut aperture may be cut out of square.
Once the aperture has been cut, check the opening size is correct.
- 8.3 Enlarge all the pre-punched 4mm dia fixing holes in the sleeve to 7mm dia. Apply a 6 - 10mm bead of intumescent mastic to the inside of the perimeter sleeve return flange.
- 8.4 Position the damper centrally within the aperture with the actuator enclosure at the bottom and horizontal blades above. A gap of 5mm between the wall and the damper sleeve on all four sides should be confirmed. The use of a 5mm spacer each side and at the bottom between the damper case and aperture would assist.
- 8.5 Using 6.5mm dia x 60mm (minimum) steel masonry fixings (e.g. multi-Monti fixings), fix the damper to the wall. Once the screw head touches the damper sleeve, apply another ½ turn.
DO NOT overtighten as this will distort the case stopping the grille from being fitted. When using an electric drill or impact drive, do so carefully as you may crease or deform the sleeve.
Once the dampers has been installed, test and inspect the damper to ensure that the blades fully travel
Once the damper has been installed, check that all the fixings are in place, and that the damper is correctly fitted into the aperture. Test and inspect the damper to ensure that the blades fully travel in both directions.
- 8.6 Check that all electrical connections are correctly made and tidy and that cable entry through the damper sleeve is sealed.
Refit the actuator cover ensuring all fixings are used.
Refit the grille using the screw fixings supplied starting with the middle fixings first followed by the outer fixings.

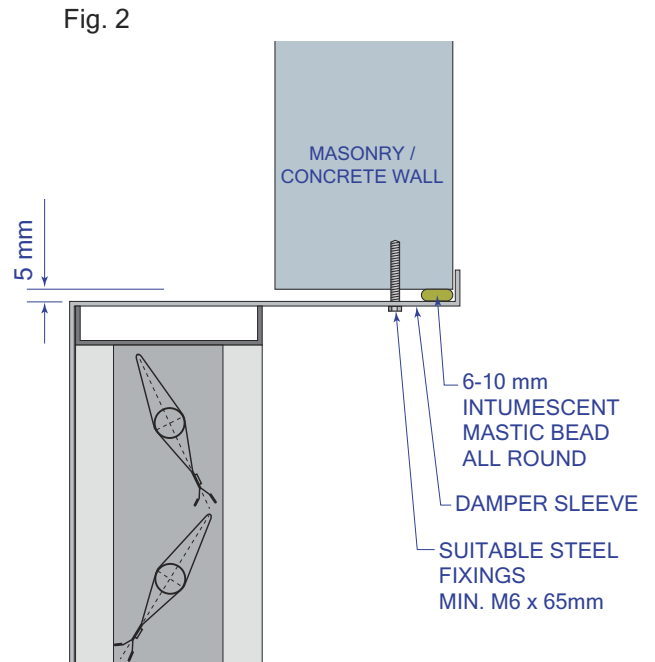

Sectional View

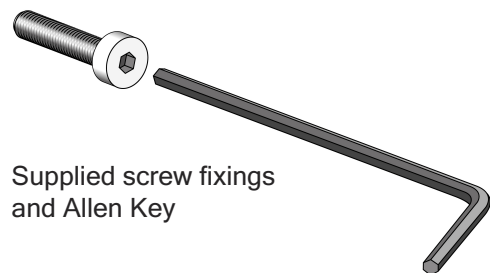

9. Grille

- 9.1 **IMPORTANT-** the BSB LDN Grille has been tested and certified with the LDN damper. Fitting a Non-BSB tested grille will invalidate the CE mark.
- 9.2 Fit the grille to the damper sleeve using 6 off M4 x 16mm screws provided for opening heights up to 1500mm and 8 off for opening heights greater than 1500mm. The screws pass through the grille blades and grille guides that align with the fixing brackets on the damper. Only the supplied 3mm a/f Allen key should be used, taking care not to scratch the grille blades. Do not use a battery drill as this will damage the captive nuts and may mark the grille.
- 9.3 Starting with the mid-height fixings, use the Allen Key provided, secure the grille to the damper sleeve before finally securing the remaining fixings. Do not fully tighten until you have checked that the grille fixings all line up and the grille is in the correct position. Check all screws are fully home, taking care not to damage the hexagonal head.

IMPORTANT
When attaching Grille, start with the mid-height brackets to set grille to correct height. Finish with the 4 corner brackets

Grille Detail

Grille fixing screw M4x16mm
painted hex cap head screws

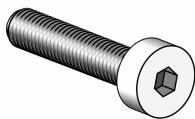

6 x Screws for heights up to 1500mm
8 x Screws for heights over 1500mm

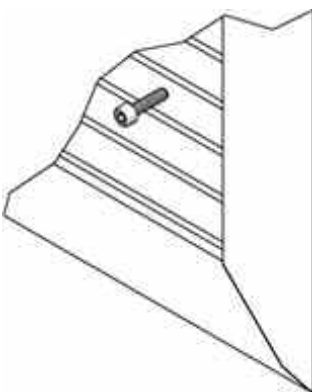

Grille fixing screws pass through the grille blades and the grille guide bracket, locating into the mating threaded damper bracket. Use only the supplied Allen Key to fit the screws.

When the installation is complete and prior to hand over the "Inspection and Handover" check list should be referred to. See page 8.

Fixing bracket with elongated slot for easy alignment.



A = Intermediate grille fixing guides
B = Corner grille fixing guides

Grille blades supported via continuous vertical rods.

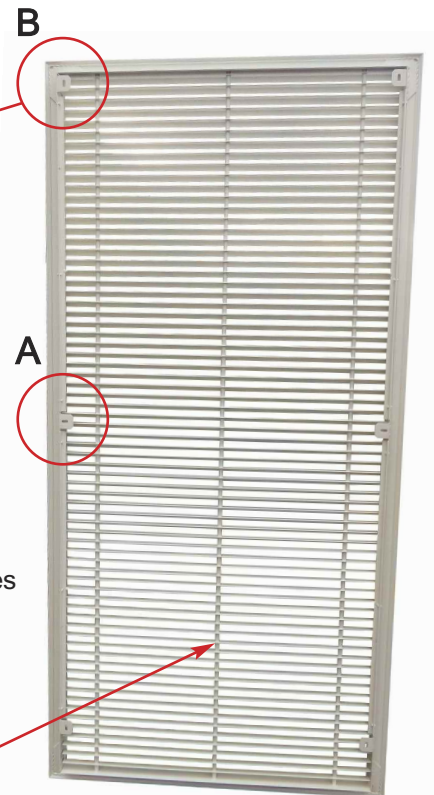

Supplied Allen key

LDN - Installation Operation and Maintenance Instructions



A brand of
MAICO

Component Identification

Fig. 4

Actuator cover.
Phillips head screws
(positions /qty will vary depending on damper size)



Fixing brackets for grille (3 or 4 per side).

Space available within actuator cover for provision of damper interface/terminal box.

Actuator cover is earthed to the damper chassis by means of M5 earth stud and cable.

WARNING: Do not exert undue force on the Earth cable by hanging the actuator cover from it.

Cable entry must be located underneath the actuator cover to suit site wiring. Refer to Page 7 for wiring schematic and use high temperature connection terminals.

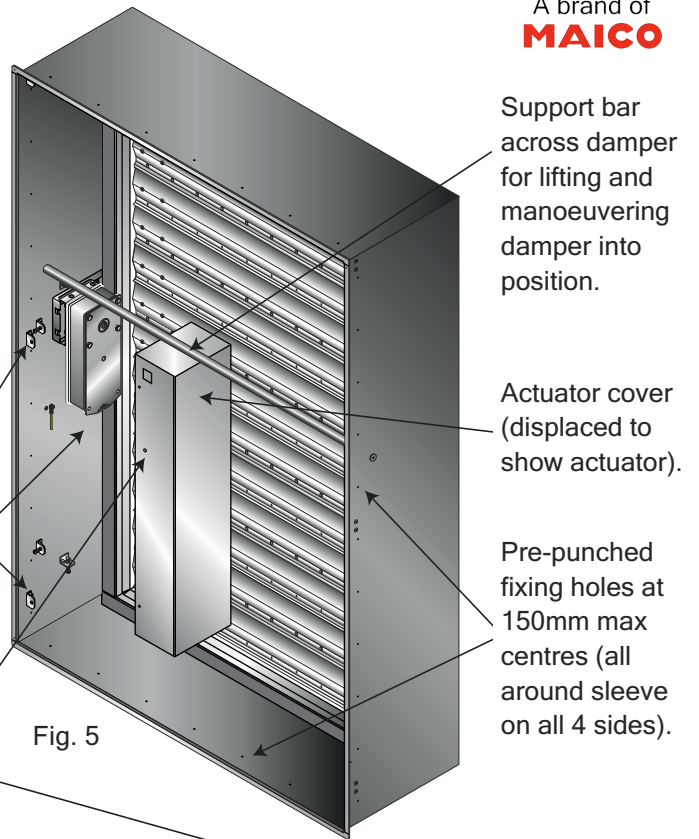

Support bar across damper for lifting and manoeuvring damper into position.

Actuator cover (displaced to show actuator).

Pre-punched fixing holes at 150mm max centres (all around sleeve on all 4 sides).

Fig. 5

Actuator Enclosure

Fig. 6

Earth cable



FITTED ACTUATORS SHOULD NOT BE DEMOUNTED WITHOUT THE PERMISSION OF THE BSB TECHNICAL SUPPORT TEAM

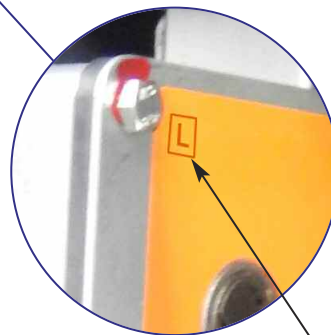
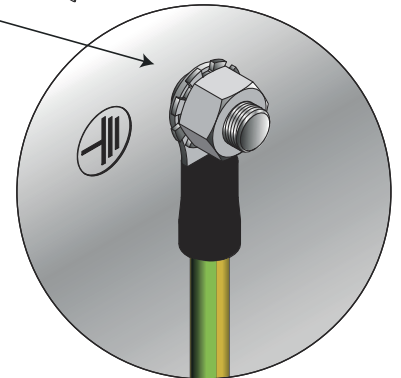

Note: **L** drive designation on actuator label outermost.

Actuator cover omitted for clarity. This is earth bonded to the M5 earth stud on the damper chassis shown above.

WARNING: Do not exert undue force on the earth cable by hanging the actuator cover from it.

Use high temperature connection terminals.

Actuator enclosure.

The actuator and cable connections are made in this enclosure.

Only permitted equipment should occupy this space and should not be used for storage.

10. Routine Inspection and Maintenance of Fire Safety Installations.

- 10.1 Routine inspection and maintenance should be carried out in accordance with BS 9999 Annex I.
- 10.2 In addition to weekly recommended checks, in 1.3.5, the actuation of all smoke control systems should be simulated once every three months. All zones should be separately tested, and it should be ensured that any fans and powered exhaust ventilators operate correctly and Smoke Control dampers function correctly.
- 10.3 Section 1.7 In addition to above, arrangements should be made for annual inspections and performance tests, by competent persons, and for any defects to be logged and the necessary action taken, and for certificates of inspection and tests to be obtained. Attention is drawn to the testing and inspection requirements of BS 7671.
- 10.4 Remove grille and visually inspect the internal damper elements for signs of damage, corrosion, obstructions, dirt/dust etc. If there are any obstructions or if the damper blades/gasket seals are dirty, they need to be cleaned and lubricated using a light spray (duck oil recommended). There should be no more than a thin film of lubricant applied. Remove all excess lubricant. It is particularly important as excess oil will tend to collect dirt and dust which will have a negative effect on dampers remaining clean. The use of heavy oil is not recommended, as this can lead to a build-up of dust/dirt on damper surfaces.
- 10.5 The damper status (blade position) needs to match the fire/smoke strategy of building control system often known as the cause and effect, i.e fully opened and fully closed. Each damper should be verified individually that it correctly responds to input and gives correct feedback to control panel. This needs to be 'signed off' by the CDM co-ordinator following the control system commissioning procedure as well as completing the installation check list.
- 10.6 Ensure the damper is left in its 'normal state'. Record all work that has been undertaken in the maintenance log. It is important to log and review maintenance frequency based on inspections and test history.

11. Commissioning

- 11.1 The damper cannot be commissioned unless its fully installed and connected to power in compliance with regulations. Dampers controlled via an interface module will need to be commissioned by a competent engineer.
- 11.2 Remove grille (if fitted—refer to page 3) by removing the discrete cap head screws behind the louvres with the 3mm A/F Allen key provided. Put grille and screws safely to one side. Verify all fixing holes in damper sleeve are occupied by suitable steel fixings and actuator cover plate is fitted.
- 11.3 Each damper should be visually verified individually that it correctly responds to inputs and gives correct feedback to the control panel. i.e. fully opened and fully closed.
- 11.4 The damper status (blade position) needs to match the fire/smoke strategy of the building control system often known as the cause and effect.

12. Fault Finding

SYMPTOM	FAULT	ACTION
NO MOVEMENT FROM ACTUATOR WHEN POWERED	NO POWER, INCORRECT POWER SUPPLY, OR WIRED INCORRECTLY	CHECK SUPPLY/WIRING
	ACTUATOR FAULTY	REFER TO BSB TECHNICAL SALES
DAMPER BLADES DO NOT TRAVEL TO FULL OPEN AND CLOSED POSITIONS	OBJECT STUCK INBETWEEN DAMPER BLADES	INSPECT DAMPER BLADES AND REMOVE OBJECT AND THEN TEST OPERATION
	DAMPER SEIZED	REFER TO BSB TECHNICAL SALES
	INCORRECT VOLTAGE APPLIED	REPLACE ACTUATOR
DAMPER OPERATION NOISY	REQUIRES CLEANING & LUBRICATING	

13. Actuator Wiring

	BE24	BE230
Electrical data		
Nominal voltage	AC 24 V, 50/60 Hz / DC 24 V	AC 230 V, 50/60 Hz
Nominal voltage range	AC 19.2...28.8V / DC 21.6...28.8V	AC 198...264 V
Power consumption motoring	12 W @ nominal torque	8 W @ nominal torque
Power consumption holding	0.5 W	0.5 W
Power consumption for wire sizing	18 VA / I _{max} . 8.2 A @ 5 ms	15 VA / I _{max} . 7.9 A @ 5 ms
Auxiliary switch	2 x 1 SPDT	2 x SPDT
Auxiliary switch contact rating (contacts gold plate on silver)	1 mA...6 A, DC 5 V...AC 250 V <input type="checkbox"/>	1 mA...6 A, DC 5 V...AC 250 V <input type="checkbox"/>
Auxiliary switch switching points	3° < / 87° < (referred to 0...90° <)	3° < / 87° < (referred to 0...90° <)
Auxiliary switch tolerance	±2	±2
Connecting cable motor	1 m, 3 x 0.75 mm ² (halogen-free)	1 m, 3 x 0.75 mm ² (halogen-free)
Connecting cable auxiliary switch	1 m, 6 x 0.75 mm ² (halogen-free)	1 m, 6 x 0.75 mm ² (halogen-free)
Functional data		
Torque (nominal torque)	Min. 40 Nm @ nominal voltage	Min. 40 Nm @ nominal voltage
Direction of rotation	Selected by mounting L/R	Selected by mounting L/R
Angle of rotation	Max. 100° < (incl. 5° < mechanical overrun on each side)	Max. 100° < (incl. 5° < mechanical overrun on each side)
Running time	<60 s for 90° <	<60 s for 90° <
Sound power level	Max. 62 dB(A)	Max. 62 dB(A)
Damper rotation BE24	Form-fit 14 mm	Form-fit 14 mm
Damper rotation BE24-12	Form fit 12 mm	Form fit 12 mm
Service life	At least 10,000 cycles	At least 10,000 cycles
Safety		
Protection class	III Safety extra-low voltage	II totally insulated <input type="checkbox"/>
Degree of protection	IP54 in all mounting positions	IP54 in all mounting positions
EMC/LVD	CE according to 89/336/EEC, 92/31/EEC, 93/68/EEC	CE according to 2004/108/EC CE according to 2006/95/EC
Ambient temperature range normal duty	-30° ...+50°C	-30° ...+50°C
Weight		
Weight	Approx. 2.7 kg	Approx. 2.7 kg

BE24 & BE230 WIRING DIAGRAMS



Wiring: See Important Safety Notice on Page 1.

Refer to Fig. 6 to designate actuator position.

- 1 + 2 Power = damper open
- 1 + 3 Power = damper closed
- 1 + 2 Signal = damper closed
- 1 + 3 Signal = damper open

BE24 On/Off Actuator

24 V Connection via safety isolating transformer

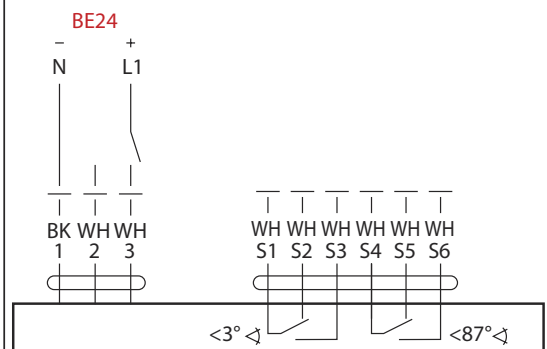

BE230 On/Off Actuator

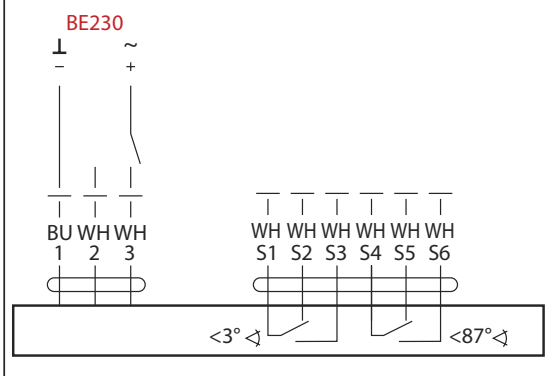

Wiring, connections, control and power should be undertaken in accordance with EN12101-9 & -10

LDN - Damper Installation Certificate



A brand of
MAICO

The installer must complete fully this installation certificate when installing fire dampers.

A separate certificate must be completed for each individual fire damper.

This certificate applies only to BSB Engineering Dampers.

No.	Question	Guidelines	Confirmed
01	Are the dampers the correct type?	Confirm damper is correct type i.e. LD or LDN series.	YES / NO
02	Are the dampers located correctly?	The damper location is to be checked against the installation drawings/details.	YES / NO
03	Have all the damper fixing holes been used?	Check that there are no unused fixing holes and use correct fixings where any are missing.	YES / NO
04	Have any fixing screws been over tightened and distorted the damper case?	Check to make sure that the damper case has not been distorted or pulled outwards towards the inner aperture, as this will impact on the damper operation. Turn screw anti-clockwise if found.	YES / NO
05	Are the dampers fitted in the correct orientation?	Confirm the damper installed the correct way up with blades in the correct orientation.	YES / NO
06	Has the actuator been connected and tested?	Check all actuator connections have been made safely and correctly to the terminal block by others.	YES / NO
07	Check the earth wire is in place and connected to the removeable cover and main damper body.	Ensure the earth wire is intact and has a good connection and has not been subject to excessive tension.	YES / NO
08	Are the damper blades undamaged?	Check position of damper blades. When closed there should be no gaps and blades should have no dents.	YES / NO
09	Has the damper been checked for internal cleanliness, free from damage and debris?	With the damper in the closed position, inspect for damage and cleanliness.	YES / NO
10	Have the damper blades been manually operated to ensure full travel can be achieved?	Ensure damper operation is free from interference and with the winding key ensure damper full travel can be achieved.	YES / NO
11	Are the grille fixing brackets on the damper damaged or cross threaded?	Check that the grille fixing screws can be inserted into the fixing bracket easily.	YES / NO
12	At the time of damper handover, is the fire barrier and penetration seal complete?	Damper installer to record on the handover register if any following trades are still to complete their activities.	YES / NO
13	Is the damper installation complete and available for handover prior to system commissioning?	Obtain the relevant acceptance of the damper installation from the Principal Designer.	YES / NO
14	Is the completed handover register cross-referenced back to the identification codes listed in the system designer's damper schedule?	Check that this action is complete.	YES / NO
15	Does the grille fit flat without distortion with all fixing screws used?	Check that the grille lays flat with no gaps to the wall and is not at an angle when fixed.	YES / NO

Damper Unique System I.D.:

Name of installation location:

Address:

Installation location identification (section/floor/room):

Damper product type:

Notes/Considerations:

Installed by:

Company Name:

Address:

Company Telephone No.:

Installers Name(s):

Installers Telephone No.:

Date of installation:

It is hereby verified that the damper detailed above has been installed and tested according to the manufacturers recommendations.

LDN Series

Lobby Damper - Ordering Codes

LDN - SIZE - BE24 - GRILLE - RAL9010

Model:
LDN Lobby Damper - Natural Vent

Structural Opening Size:
Width x Height
Min. (mm) 300W x 1000H
Max. (mm) 1100W x 2300H

Grille Colour:
RAL9010 White Standard
SPECIAL Please specify

Actuator Options:
BE24 Open/Closed
BE230 Open/Closed

Other Air, Fire and Smoke Control Products in the BSB Range:



For full details of the complete BSB Product Range, please refer to our individual product brochures, sales office or website.



A brand of
MAICO

BSB Engineering Services Limited

Unit 56, Trinity Trade Centre, Mill Way, Sittingbourne, Kent ME10 2PD, UK • Tel: +44 (0)1795 422609

For purchase orders and order related enquiries, please email: orders@bsb-dampers.co.uk

For pricing, technical and general enquiries, please email: enquiries@bsb-dampers.co.uk

Website: www.bsb-dampers.co.uk • A member of the Maico group

BSB Engineering Services Ltd. reserves the right to modify or withdraw any specification without prior notice that may result from continuous product development. The information contained within this brochure is correct at the time of going to press. (LDN-04-2022)



HEVAC

bre

ADCAS
THE VOICE OF THE DUCTWORK INDUSTRY

SMOKE CONTROL ASSOCIATION



Assessed to ISO 9001:2015
Certificate No. 1464

MADE IN BRITAIN