

LD and LDN Series



Lobby Dampers

- LD Series - Mechanical Ventilation
- LDN Series - Natural Vent and Mechanical Ventilation
- Suitable for environmental and smoke control extract systems
- Fire resistance tested to EN 1366-10
- Classified according to EN 13501-4
- CE marked to EN 12101-8
- Case leakage - Class C EN 1751
- Blade leakage - Class 2 EN 1751
- Single and multicompartment use tested to EN 12101-8
- Easy Fix® fascia grille



A brand of
MAICO

MANUFACTURERS OF AIR, FIRE AND SMOKE CONTROL PRODUCTS

LD and LDN Series

Lobby Dampers



Introduction

The LD and LDN series dampers have been designed for smoke evacuation and control within lobbies and are installed into extract shafts in multi-level buildings, to maintain tenable conditions in the common escape routes in the event of a fire.

LD series dampers are designed to work in fan power extract systems. Air is pulled through the damper and into the extract shaft.

LDN series dampers work in natural draft (stack effect) ventilation which requires a minimum free area of one metre square to comply with current standards and Approved Document B specification.

These dampers are for dry wall or masonry/ concrete construction.

The Lobby Damper series comprises of 2 models

- LD—Mechanical ventilation applications
- LDN—Naturally ventilated applications

Size Range (finished aperture size)

Product	Minimum		Maximum	
	Width	Height	Width	Height
LD	400mm	600mm	1200mm	1425mm
LDN	300mm	1000mm	1100mm	2300mm

Actual sizes are -10mm below aperture nominal size.

Sizes are typically available in 50mm increments.

Available to special order on application.

Design

The lobby sleeved damper consists of two parts. The damper within a sleeve and a grille room side for ductless applications.

The main sleeved damper with peripheral flange allows it to be fitted flush into the builder's prepared aperture. The fitted internal actuator is used to drive the damper blades from the normal closed position to the fully open position on receipt of a signal from a fire/smoke control and detection system. Closed blade surfaces are painted matt black to allow this product to be inconspicuous behind the EASY FIX® grille.

LD units have vertical damper blades whilst the LDN has horizontal damper blades.

The horizontal blade grille has been designed to maximise the airflow with minimal pressure loss. The grille is affixed to the damper with concealed colour matched fixings.

Function

The dampers are typically closed in normal operation. Where a fire or smoke is detected, the damper on the level of the fire would receive an instruction from the control system to open to vent the smoke and gases into the smoke shaft.

The Dampers on all other levels remain closed, thus preventing the spread of fire from the riser on those levels.

Testing and Conformities

- Damper/Grille tested to EN1366-10*
- Damper/Grille certificated to EN12101-8*
- Damper/Grille classified to EN 13501-4*

Achieving:

Tested result

E (120Vew i→o) S 1000 C 10,000 AA Multi

*IMPORTANT. The grille forms part of the fully tested solution. EN1666-10 states that if the grille is to be fitted within 200mm of the damper, then it must be tested with the damper. BSB have fire tested the damper with the grille fitted to both the LD and LDN damper.

Features and Benefits

- Suitable for dry line walls and masonry walls
- CE marked
- 120 minute rated
- Mechanical and natural vent options
- Large single section motorised format
- Damper and matching grille combined tested
- Casing pilot fixing holes assists correct installation
- Matt black painted internal surfaces
- Enclosed easy access actuators
- Easy Fix® fascia grille
- Discrete installation
- 24 volt and 230 volt actuator options

Damper and Casing

Opposed interlocking Multi-blade damper with motor open/ motor closed actuator.

Damper assembly has pre-punched holes for affixing into builders-work prepared aperture.

Removable actuator cover plate. (LD in base of assembly, LDN left side when viewed with grille removed).

Provision for electrical connection box (by others) if required.

Visible internal surfaces of damper and sleeve are painted matt black.

Grille

The matched aluminium grille forms part of the tested solution to meet EN12101-8.

- Material Aluminium Alloy 6063
- Blade pitch 19mm
- Blade angle 40°
- Paint finish - RAL9010 as standard (other colours to special order)
- Fixing - EASY FIX® Concealed rear brackets for affixing grille to damper (colour matched fixings supplied).

Damper Specification

CE marked LD & LDN dampers certificated to EN12101-8, tested to EN1366-10 and classified to EN13501-4.

Achieving:

E (120 Vew i→o) S 1000 C10,000 AA Multi

Enclosed actuator and linkage mechanism.

Casing

1.5mm galvanised steel (BS EN10346 DX51D+Z275) frame with fully seam welded corners along the entire depth to produce a rigid and air-tight construction.

Matt Black paint is applied to the internals for an inconspicuous installation.

Blades

0.7mm galvanised (BS EN10346 DX51D+Z275) double skin matt black painted aerofoil 100mm pitch damper blades which interlock when closed.

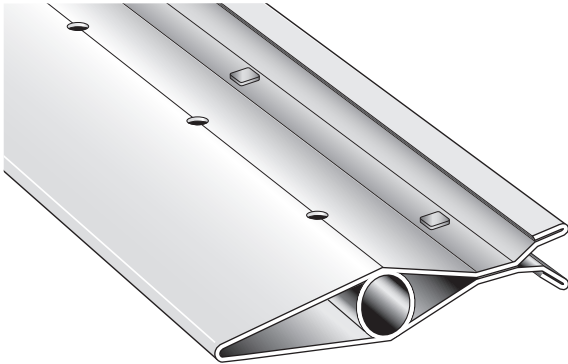

Actuator

24V AC/DC or 230V AC motor open/motor closed actuator with volt free monitoring contacts.

Actuator is on lobby side, concealed from view behind a black painted removable cover and can be manually operated if required.

Fixing

Pre-punched fixing holes in the damper sleeve on all four sides provide for easy installation.

Perimeter Gasket

0.4mm type 301 st/st (1.4310 BS EN10088-2) gasket around entire internal perimeter.

Enclosed actuator and linkage mechanism.

Damper Specification

The Smoke Control series LD and LDN damper shall be certified to ISO 9001 and pass the tested requirements stated in EN 1366-10.

CE marked LD & LDN dampers certificated to EN12101-8.

The test requirements shall allow for installation within a dry line wall and masonry walls.

Designed for smoke evacuation and control within lobbies and are installed within extract shaft walls in multi-level buildings, to maintain tenable conditions in escape routes.

The damper and grille shall be a fully tested product tested to EN 1366-10, certified to EN 12101-8, and classified to EN 13501-4 achieving:

E (120 Vew i→o) S 1000 C10,000 AA Multi

Dampers shall be typically closed in normal operation and move to the open position via a drive open/drive closed (non spring activated) actuator to vent smoke and gases into the smoke shaft.

The smoke control damper shall have a tested installation method that matches the requirement of the supporting construction into which it is built.

Application

LD and LDN dampers have been designed for smoke evacuation and control within lobbies and are suitable for dry line walls and masonry walls.

Both the LD and LDN dampers can be used for Natural ventilation and Mechanical ventilation. So why have both?

The LDN series damper has a greater free area than the LD series damper and can be manufactured with a greater height spectrum to accommodate extract specification volumes.

The LD series damper has a more practical design for modern high rise properties where space can be at a premium.

Natural ventilation dampers are required to have a minimum free area of 1.5m² whereas mechanical ventilation typically would have a minimum free area of 0.6m² and would be used where space is at a premium.

Natural smoke ventilation systems work by the inherent buoyancy of hot smoke which will be drawn up the shaft. Mechanical ventilation systems are assisted by a fan at the top of the shaft which allows for a greater volume to be extracted than the natural ventilation system, thus a small free area damper is required.

LD and LDN Series

Lobby Dampers

Dimensions

LD Series Damper

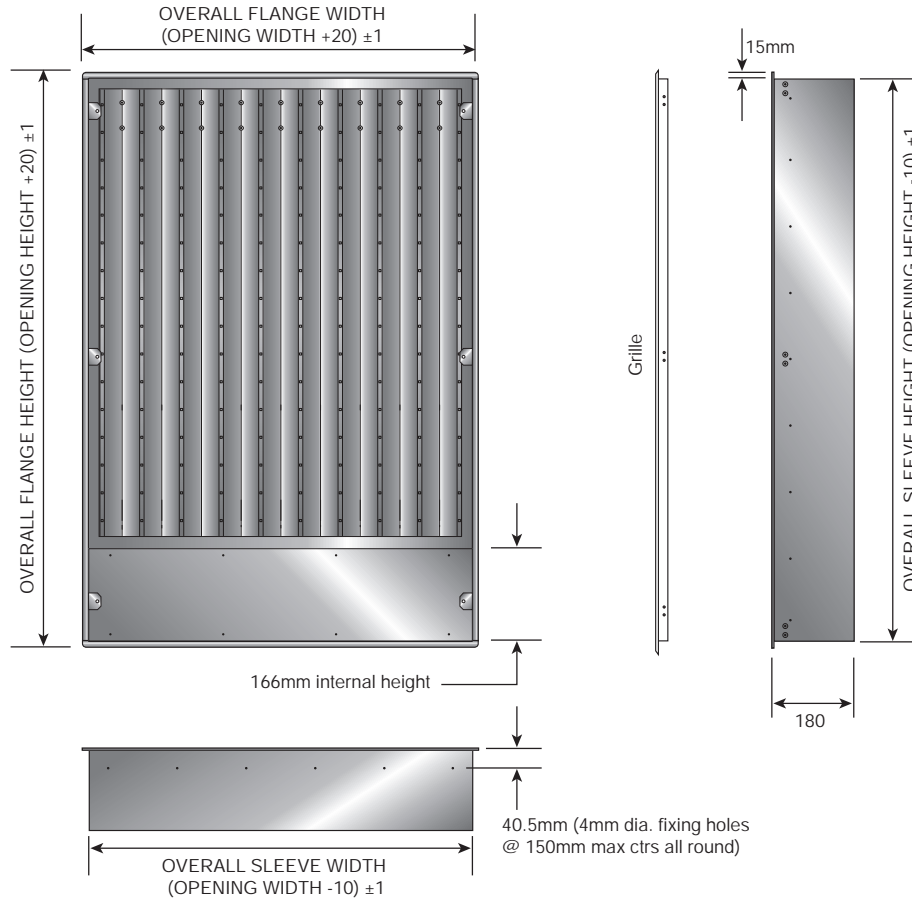

LDN Series Damper

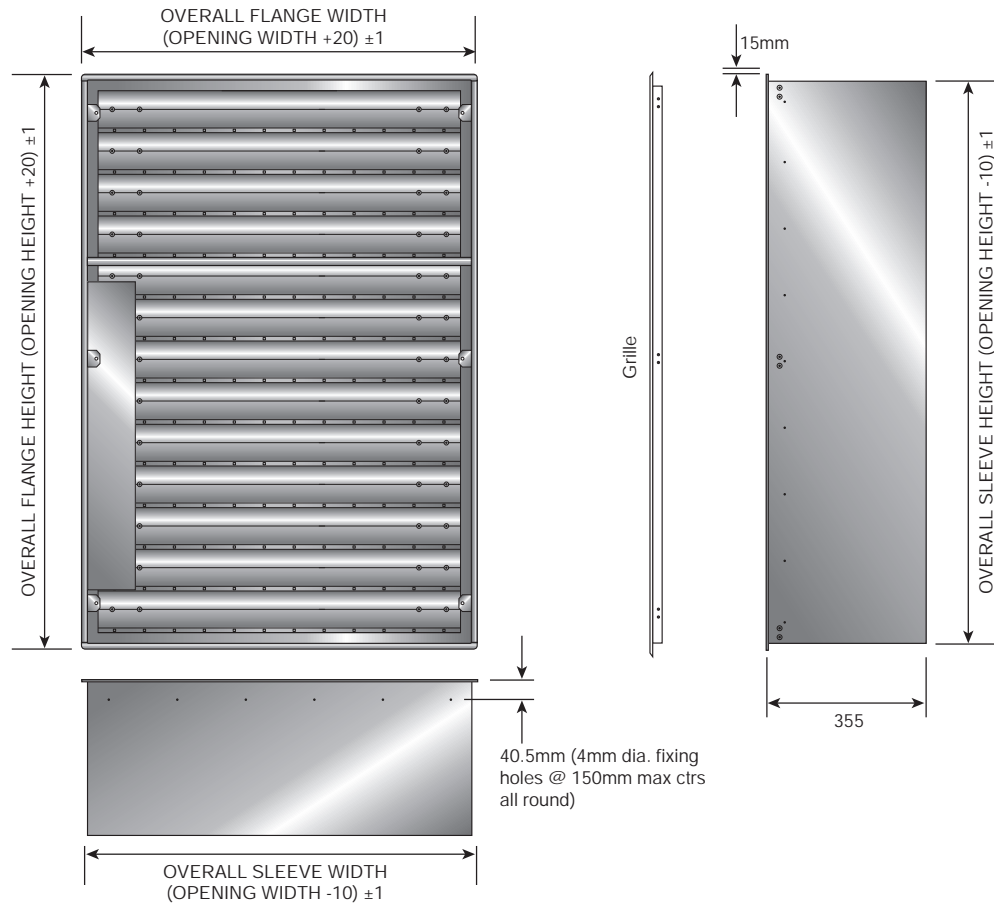

LD Series Damper Pressure Drop

LD Series Damper and Grille Combined Pressure Drop

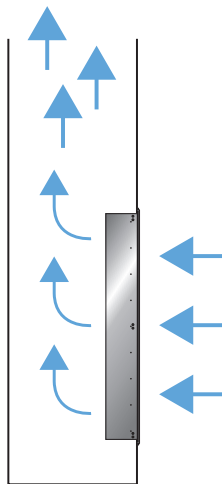
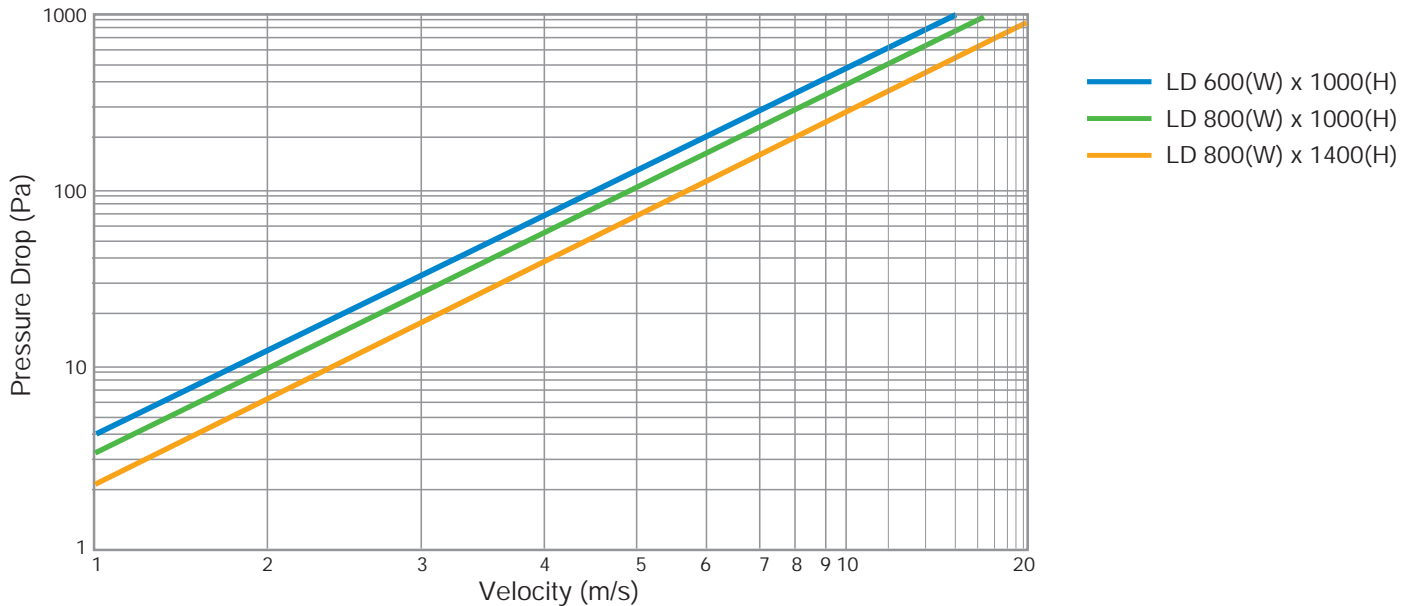

LD Series Dampers were aerodynamically tested within a test duct as shown.

The airflow direction is shown by the arrows.

LD Series Damper Weight Chart (kg) These values are approximate

Height (mm)	Damper width (mm)								
	400	500	600	700	800	900	1000	1100	1200
600	18.0	21.0	23.0	26.0	29.0	32.0	34.0	37.0	40.0
700	20.0	23.0	26.0	29.0	32.0	34.0	37.0	40.0	43.0
800	21.0	25.0	28.0	31.0	34.0	37.0	41.0	44.0	47.0
900	23.0	27.0	30.0	33.0	37.0	40.0	44.0	47.0	51.0
1000	25.0	29.0	32.0	36.0	39.0	43.0	47.0	50.0	54.0
1100	27.0	30.0	34.0	38.0	42.0	46.0	50.0	54.0	57.0
1200	28.0	33.0	37.0	41.0	45.0	49.0	53.0	57.0	61.0
1300	30.0	34.0	39.0	43.0	47.0	52.0	56.0	60.0	65.0
1400	32.0	36.0	41.0	46.0	50.0	55.0	59.0	64.0	68.0

LD and LDN Series

Lobby Dampers

LDN Series Damper Pressure Drop

LDN Series Damper and Grille Combined Pressure Drop

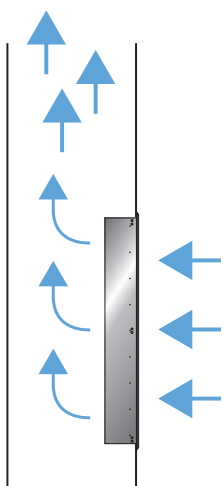
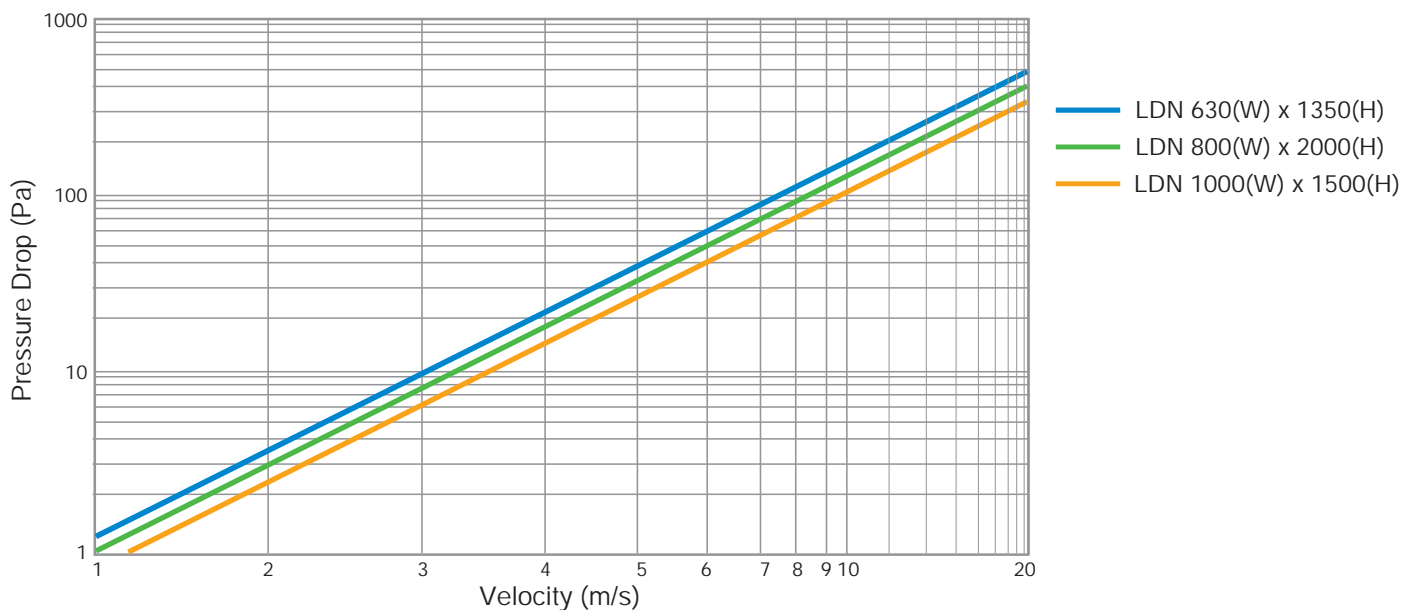

LD Series Dampers were aerodynamically tested within a test duct as shown. The airflow direction is shown by the arrows.

LDN Series Damper Weight Chart (kg) These values are approximate

Height (mm)	Damper width (mm)								
	300	400	500	600	700	800	900	1000	1100
1000	31.0	35.0	38.0	42.0	45.0	48.0	52.0	55.0	58.0
1100	34.0	37.0	41.0	44.0	48.0	52.0	55.0	59.0	62.0
1200	36.0	40.0	43.0	47.0	51.0	55.0	58.0	62.0	66.0
1300	38.0	42.0	46.0	50.0	54.0	58.0	62.0	66.0	70.0
1400	40.0	44.0	49.0	53.0	57.0	61.0	65.0	69.0	73.0
1500	42.0	47.0	51.0	55.0	60.0	64.0	68.0	73.0	77.0
1600	45.0	49.0	54.0	58.0	63.0	67.0	72.0	76.0	81.0
1700	47.0	52.0	56.0	61.0	66.0	70.0	75.0	80.0	85.0
1800	49.0	54.0	59.0	64.0	69.0	74.0	79.0	84.0	88.0
1900	51.0	56.0	62.0	67.0	72.0	77.0	82.0	87.0	92.0
2000	53.0	59.0	64.0	69.0	75.0	80.0	85.0	91.0	96.0
2100	56.0	61.0	67.0	72.0	77.0	83.0	88.0	94.0	99.0
2200	58.0	64.0	69.0	75.0	80.0	86.0	92.0	98.0	103.0
2300	60.0	66.0	72.0	78.0	83.0	89.0	95.0	101.0	107.0

LD Series Damper Technical Information

LD Series Free Area m² (Aperture size in mm)

	400	500	600	700	800	900	1000	1100	1200
600	0.06	0.11	0.13	0.16	0.19	0.21	0.24	0.27	0.29
700	0.08	0.14	0.17	0.21	0.24	0.28	0.31	0.34	0.38
800	0.11	0.17	0.21	0.26	0.30	0.34	0.38	0.42	0.47
900	0.13	0.20	0.25	0.30	0.35	0.40	0.45	0.50	0.55
1000	0.16	0.23	0.29	0.35	0.41	0.47	0.52	0.58	0.64
1100	0.18	0.27	0.33	0.40	0.46	0.53	0.60	0.66	0.73
1200	0.21	0.30	0.37	0.45	0.52	0.59	0.67	0.74	0.82
1300	0.23	0.33	0.41	0.49	0.58	0.66	0.74	0.82	0.90
1400	0.25	0.36	0.45	0.54	0.63	0.72	0.81	0.90	0.99
1425	0.26	0.37	0.46	0.55	0.65	0.74	0.83	0.92	1.01

Free Area Colour Key
Less than 0.4 msq
0.4 - 0.59 msq
0.6 - 0.99 msq
1.00 msq >

The damper free area quoted is the geometric free area meeting building regulation compliance as defined in Appendix D of Approved Document B1 & B2 of the Building Regulations.

The free area is based on the clear damper internal cross sectional area in the throat of the damper, taking into account the damper blades, gasket, and actuator pocket.

LDN Series Damper Technical Information

LDN Series Free Area m² (Aperture size in mm)

	300	350	400	450	500	550	600	650	700	750	800	850	900	950	1000	1050	1100
1000	0.14	0.18	0.21	0.25	0.28	0.32	0.36	0.39	0.43	0.46	0.50	0.53	0.57	0.61	0.64	0.68	0.71
1050	0.14	0.18	0.21	0.25	0.28	0.32	0.36	0.39	0.43	0.46	0.50	0.53	0.57	0.61	0.64	0.68	0.71
1100	0.16	0.20	0.24	0.28	0.32	0.35	0.39	0.43	0.47	0.51	0.55	0.59	0.63	0.67	0.71	0.75	0.79
1150	0.16	0.20	0.24	0.28	0.32	0.35	0.39	0.43	0.47	0.51	0.55	0.59	0.63	0.67	0.71	0.75	0.79
1200	0.17	0.22	0.26	0.30	0.35	0.39	0.43	0.48	0.52	0.56	0.61	0.65	0.70	0.74	0.78	0.83	0.87
1250	0.17	0.22	0.26	0.30	0.35	0.39	0.43	0.48	0.52	0.56	0.61	0.65	0.70	0.74	0.78	0.83	0.87
1300	0.19	0.24	0.28	0.33	0.38	0.43	0.47	0.52	0.57	0.62	0.66	0.71	0.76	0.81	0.85	0.90	0.95
1350	0.19	0.24	0.28	0.33	0.38	0.43	0.47	0.52	0.57	0.62	0.66	0.71	0.76	0.81	0.85	0.90	0.95
1400	0.20	0.25	0.31	0.36	0.41	0.46	0.51	0.56	0.62	0.67	0.72	0.77	0.82	0.87	0.92	0.98	1.03
1450	0.20	0.25	0.31	0.36	0.41	0.46	0.51	0.56	0.62	0.67	0.72	0.77	0.82	0.87	0.92	0.98	1.03
1500	0.22	0.27	0.33	0.39	0.44	0.50	0.55	0.61	0.66	0.72	0.77	0.83	0.88	0.94	1.00	1.05	1.11
1550	0.22	0.27	0.33	0.39	0.44	0.50	0.55	0.61	0.66	0.72	0.77	0.83	0.88	0.94	1.00	1.05	1.11
1600	0.23	0.29	0.35	0.41	0.47	0.53	0.59	0.65	0.71	0.77	0.83	0.89	0.95	1.01	1.07	1.13	1.19
1650	0.23	0.29	0.35	0.41	0.47	0.53	0.59	0.65	0.71	0.77	0.83	0.89	0.95	1.01	1.07	1.13	1.19
1700	0.25	0.31	0.38	0.44	0.50	0.57	0.63	0.69	0.76	0.82	0.88	0.95	1.01	1.07	1.14	1.20	1.26
1750	0.25	0.31	0.38	0.44	0.50	0.57	0.63	0.69	0.76	0.82	0.88	0.95	1.01	1.07	1.14	1.20	1.26
1800	0.27	0.33	0.40	0.47	0.53	0.60	0.67	0.74	0.80	0.87	0.94	1.01	1.07	1.14	1.21	1.28	1.34
1850	0.27	0.33	0.40	0.47	0.53	0.60	0.67	0.74	0.80	0.87	0.94	1.01	1.07	1.14	1.21	1.28	1.34
1900	0.28	0.35	0.42	0.49	0.57	0.64	0.71	0.78	0.85	0.92	0.99	1.07	1.14	1.21	1.28	1.35	1.42
1950	0.28	0.35	0.42	0.49	0.57	0.64	0.71	0.78	0.85	0.92	0.99	1.07	1.14	1.21	1.28	1.35	1.42
2000	0.30	0.37	0.45	0.52	0.60	0.67	0.75	0.82	0.90	0.97	1.05	1.12	1.20	1.27	1.35	1.43	1.50
2050	0.30	0.37	0.45	0.52	0.60	0.67	0.75	0.82	0.90	0.97	1.05	1.12	1.20	1.27	1.35	1.43	1.50
2100	0.31	0.39	0.47	0.55	0.63	0.71	0.79	0.87	0.95	1.02	1.10	1.18	1.26	1.34	1.42	1.50	1.58
2150	0.31	0.39	0.47	0.55	0.63	0.71	0.79	0.87	0.95	1.02	1.10	1.18	1.26	1.34	1.42	1.50	1.58
2200	0.33	0.41	0.49	0.58	0.66	0.74	0.83	0.91	0.99	1.08	1.16	1.24	1.33	1.41	1.49	1.57	1.66
2250	0.33	0.41	0.49	0.58	0.66	0.74	0.83	0.91	0.99	1.08	1.16	1.24	1.33	1.41	1.49	1.57	1.66
2300	0.34	0.43	0.52	0.60	0.69	0.78	0.87	0.95	1.04	1.13	1.21	1.30	1.39	1.48	1.56	1.65	1.74

Free Area Colour Key
Less than 0.4 msq
0.4 - 0.59 msq
0.6 - 0.99 msq
1.00 - 1.49 msq
1.50 - 1.74 msq

The damper free area quoted is the geometric free area meeting building regulation compliance as defined in Appendix D of Approved Document B1 & B2 of the Building Regulations.

The free area is based on the clear damper internal cross sectional area in the throat of the damper, taking into account the damper blades, gasket, and actuator pocket.

INSTALLATION METHOD

LD DRY WALL

PLEASE REFER TO INSTALLATION, OPERATING AND MAINTENANCE DOCUMENT FOR DETAILED INFORMATION.
GRILLE OMITTED FOR CLARITY.
THIS IS AN UN-DUCTED INSTALLATION.
REFER TO ADB FOR RECOMMENDED DAMPER POSITIONING.

LD M9

VIEW A

TESTED WALL THICKNESS 120MM

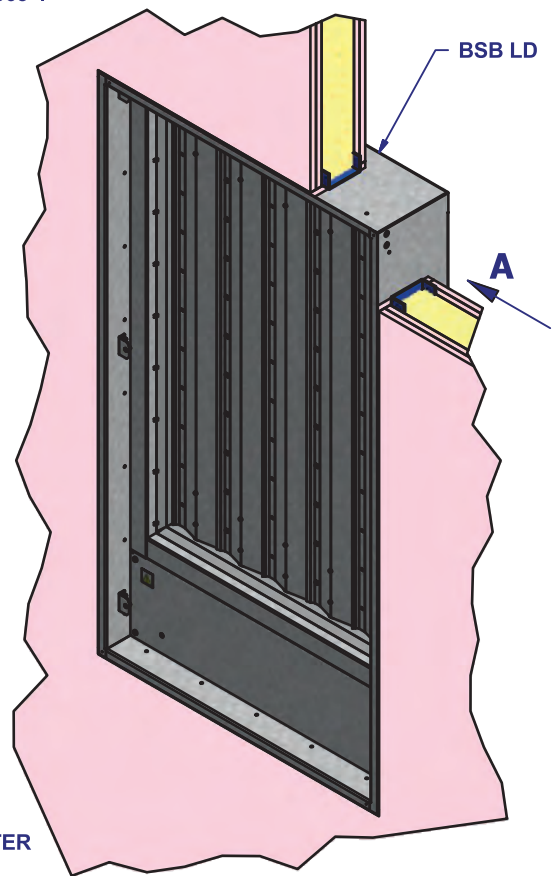
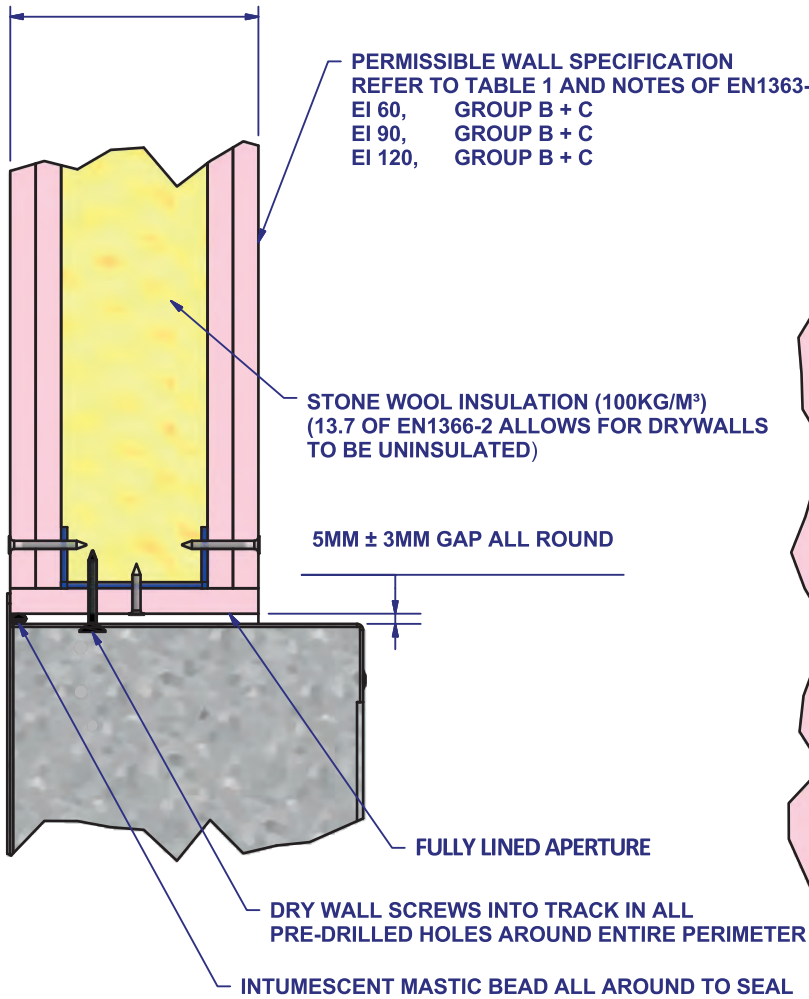

A MINIMUM OF 75MM SEPARATION BETWEEN SMOKE CONTROL DAMPER AND ADJACENT WALL OR FLOOR,
AND 200MM BETWEEN SINGLE SECTION DAMPERS.

TESTED INSTALLATION METHOD SHOWN. DIFFERING INSTALLATION METHODS TO THIS MUST BE APPROVED BY
THE BUILDING CONTROL AUTHORITY (BCA) BEFORE PROCEEDING. THEY WILL NEED TO REFER TO THIS DOCUMENT
AND I, O & M IN ORDER TO CONSIDER APPROVAL.

Aperture size (Wmm x Hmm) 400 x 600 to 1200 x 1425

BSB LD



120 MINUTES FIRE/SMOKE RESISTANCE
E 120 (Vew i → o) S

www.bsb-dampers.co.uk

TESTED TO EN 1366-10
CLASSIFIED TO EN 13501-4



A brand of
MAICO

INSTALLATION METHOD

LD MASONRY WALL



A brand of
MAICO

PLEASE REFER TO INSTALLATION, OPERATING AND MAINTENANCE DOCUMENT FOR DETAILED INFORMATION.
GRILLE OMITTED FOR CLARITY.
THIS IS AN UN-DUCTED INSTALLATION.
REFER TO ADB FOR RECOMMENDED DAMPER POSITIONING.

LD M10

USE LINTEL TO SPAN TOP OF APERTURE

MASONRY/CONCRETE WALL

VIEW A

MINIMUM WIDTH TO SUIT FIRE RESISTANCE TIME
EQUAL OR GREATER THAN THE FIRE RESISTANCE
REQUIRED FOR THE DAMPER INSTALLATION

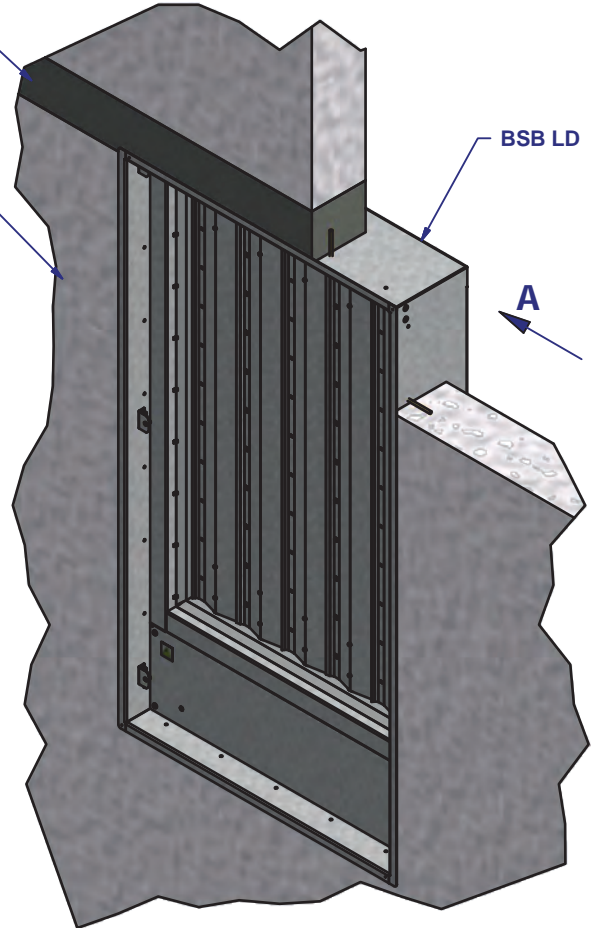
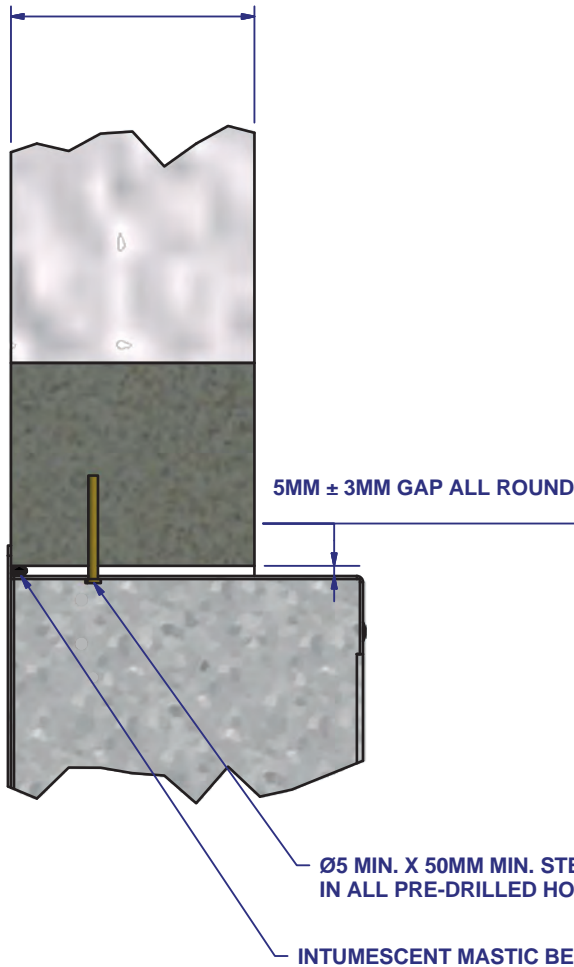

A MINIMUM OF 75MM SEPARATION BETWEEN SMOKE CONTROL DAMPER AND ADJACENT WALL OR FLOOR,
AND 200MM BETWEEN SINGLE SECTION DAMPERS.
*USING DIRECT FIELD OF APPLICATION FROM EN 1366-10.

TESTED INSTALLATION METHOD SHOWN*. DIFFERING INSTALLATION METHODS TO THIS MUST BE APPROVED BY
THE BUILDING CONTROL AUTHORITY (BCA) BEFORE PROCEEDING. THEY WILL NEED TO REFER TO THIS DOCUMENT
AND I, O & M IN ORDER TO CONSIDER APPROVAL.

Aperture size (Wmm x Hmm) 400 x 600 to 1200 x 1425

BSB LD



120 MINUTES FIRE/SMOKE RESISTANCE
E 120 (Vew i → o) S

www.bsb-dampers.co.uk

TESTED TO EN 1366-10*
CLASSIFIED TO EN 13501-4

0278

INSTALLATION METHOD

LDN DRY WALL

PLEASE REFER TO INSTALLATION, OPERATING AND MAINTENANCE DOCUMENT FOR DETAILED INFORMATION.
GRILLE OMITTED FOR CLARITY.
THIS IS AN UN-DUCTED INSTALLATION.
REFER TO ADB FOR RECOMMENDED DAMPER POSITIONING.

LDN M9

VIEW A

TESTED WALL THICKNESS 120MM

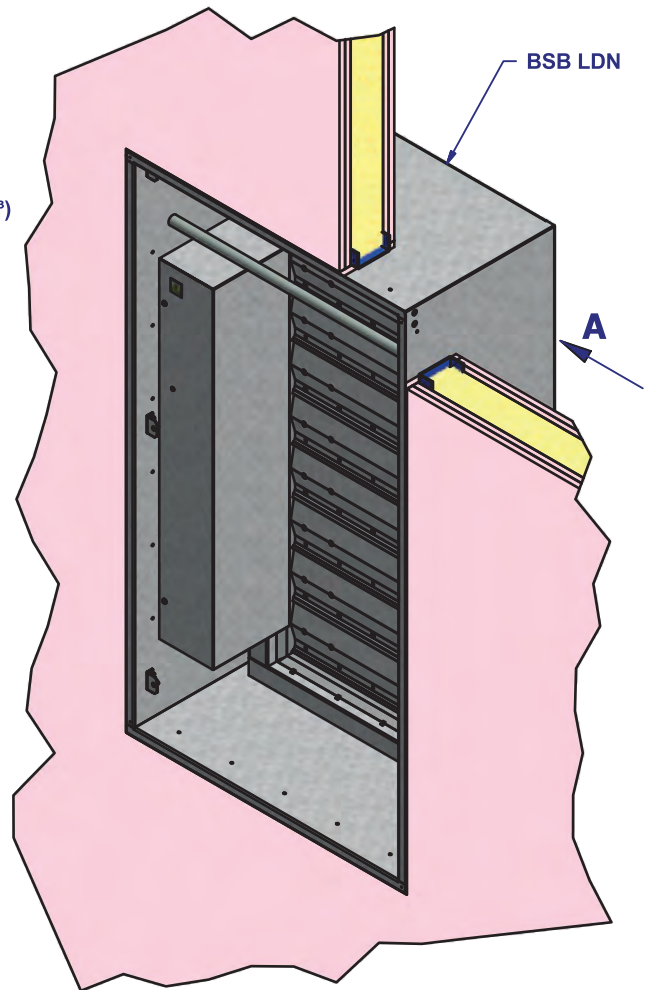
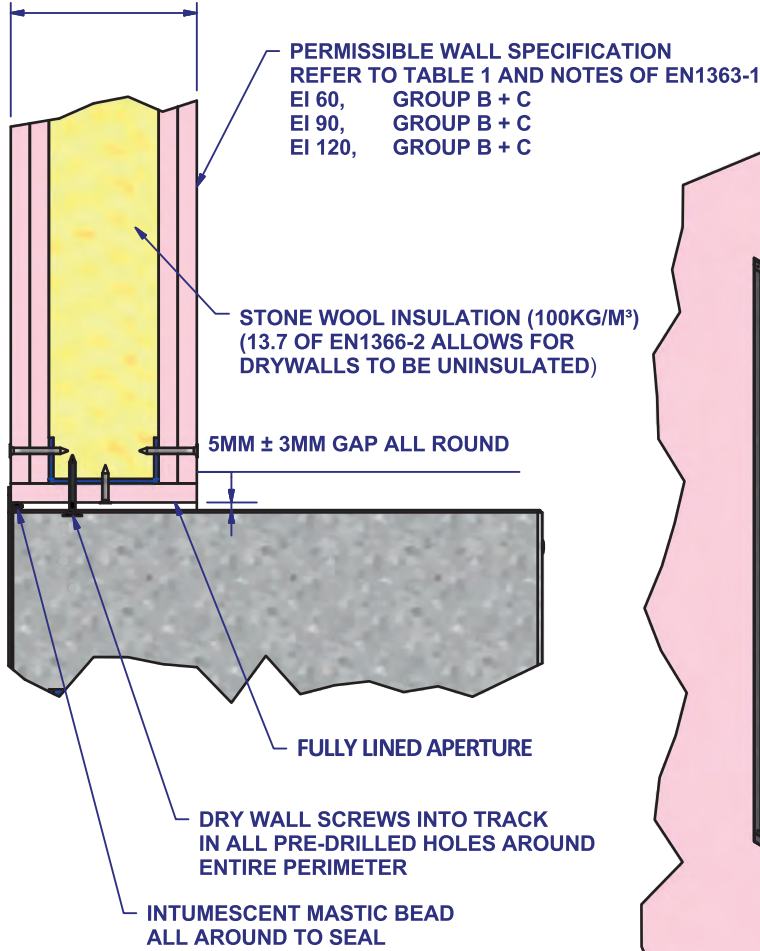

A MINIMUM OF 75MM SEPARATION BETWEEN SMOKE CONTROL DAMPER AND ADJACENT WALL OR FLOOR,
AND 200MM BETWEEN SINGLE SECTION DAMPERS.

TESTED INSTALLATION METHOD SHOWN. DIFFERING INSTALLATION METHODS TO THIS MUST BE APPROVED BY
THE BUILDING CONTROL AUTHORITY (BCA) BEFORE PROCEEDING. THEY WILL NEED TO REFER TO THIS DOCUMENT
AND I, O & M IN ORDER TO CONSIDER APPROVAL.

Aperture size (Wmm x Hmm) 300 x 1000 to 1100 x 2300

BSB LDN



120 MINUTES FIRE/SMOKE RESISTANCE
E 120 (Vew i → o) S

www.bsb-dampers.co.uk

TESTED TO EN 1366-10
CLASSIFIED TO EN 13501-4



A brand of
MAICO

INSTALLATION METHOD

LDN MASONRY WALL



A brand of
MAICO

PLEASE REFER TO INSTALLATION, OPERATING AND MAINTENANCE DOCUMENT FOR DETAILED INFORMATION.
GRILLE OMITTED FOR CLARITY.
THIS IS AN UN-DUCTED INSTALLATION.
REFER TO ADB FOR RECOMMENDED DAMPER POSITIONING.

LDN M10

USE LINTEL TO SPAN TOP OF APERTURE

MASONRY/CONCRETE WALL

BSB LDN

VIEW A

MINIMUM WIDTH TO SUIT FIRE RESISTANCE TIME
EQUAL OR GREATER THAN THE FIRE RESISTANCE
REQUIRED FOR THE DAMPER INSTALLATION

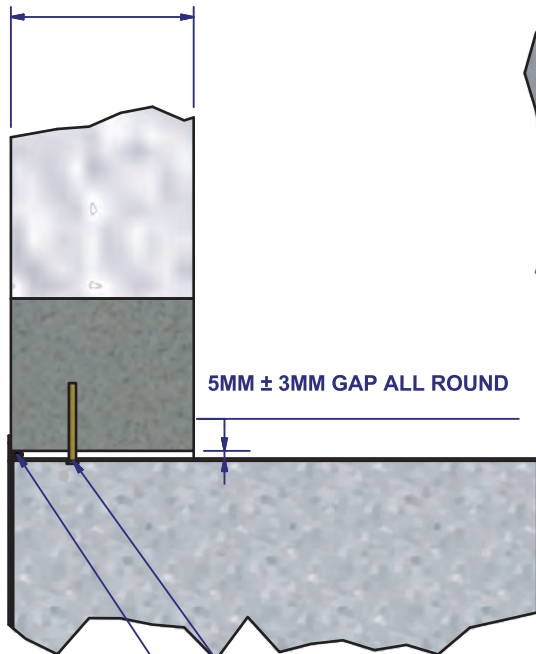

5MM ± 3MM GAP ALL ROUND

Ø5 MIN. X 50MM MIN. STEEL FIXINGS INTO WALL
IN ALL PRE-DRILLED HOLES AROUND ENTIRE PERIMETER

INTUMESCENT MASTIC BEAD ALL AROUND TO SEAL

A MINIMUM OF 75MM SEPARATION BETWEEN SMOKE CONTROL DAMPER AND ADJACENT WALL OR FLOOR,
AND 200MM BETWEEN SINGLE SECTION DAMPERS.
*USING DIRECT FIELD OF APPLICATION FROM EN 1366-10.

TESTED INSTALLATION METHOD SHOWN*. DIFFERING INSTALLATION METHODS TO THIS MUST BE APPROVED BY
THE BUILDING CONTROL AUTHORITY (BCA) BEFORE PROCEEDING. THEY WILL NEED TO REFER TO THIS DOCUMENT
AND I, O & M IN ORDER TO CONSIDER APPROVAL.

Aperture size (Wmm x Hmm) 300 x 1000 to 1100 x 2300

BSB LDN



120 MINUTES FIRE/SMOKE RESISTANCE
E 120 (Vew i → o) S

www.bsb-dampers.co.uk

TESTED TO EN 1366-10*
CLASSIFIED TO EN 13501-4

0278

LD and LDN Series Lobby Dampers

Actuator Details

Actuators are factory fitted and are drive open and drive closed function by means of a 2 wire system. Available as 24 volt AC/DC or 230 volt AC voltage. The actuators drive the damper when a power supply is applied to either terminals 1 & 2 to drive open or terminals 1 & 3 to drive closed.

Volt free contacts S1 to S6 provide damper open or closed status which should be relayed back to the panel.

Secondary Power Source

Dampers shall be supported by a secondary power source as stated in EN 12101-10.

BE24 & BE230 WIRING DIAGRAMS



Wiring: See Important Safety Notice on Page 1.

Refer to Fig. 6 to designate actuator position.

- 1 + 2 Power = damper open
- 1 + 3 Power = damper closed
- 1 + 2 Signal = damper closed
- 1 + 3 Signal = damper open

BE24 On/Off Actuator

24 V Connection via safety isolating transformer

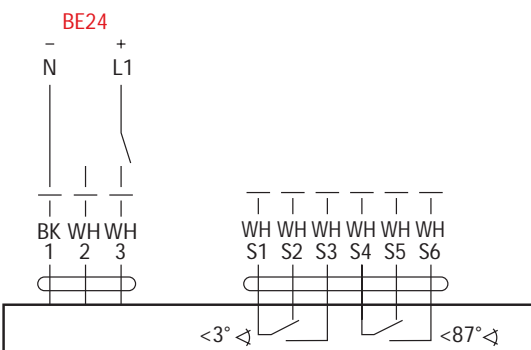

BE230 On/Off Actuator

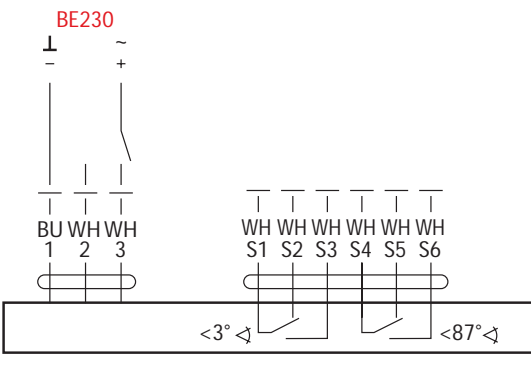

Wiring, connections, control and power should be undertaken in accordance with EN12101-9 & -10

Actuator Features

- Responsive to inputs from the control system.
- Auxiliary contacts for open and closed status.
- Actuator hidden from view with easy access for maintenance via removable panel.
- 1m power and signal cables provided.
- Provision for control interface device (by others) has been allowed for within the damper actuator pocket using 4off M4 6mm raised pillars.

Electrical data	BE24	BE230
Nominal voltage	AC 24 V, 50/60 Hz / DC 24 V	AC 230 V, 50/60 Hz
Nominal voltage range	AC 19.2...28.8V / DC 21.6...28.8V	AC 198...264 V
Power consumption motoring	12 W @ nominal torque	8 W @ nominal torque
Power consumption holding	0.5 W	0.5 W
Power consumption for wire sizing	18 VA / I _{max} . 8.2 A @ 5 ms	15 VA / I _{max} . 7.9 A @ 5 ms
Auxiliary switch	2 x 1 SPDT	2 x SPDT
Auxiliary switch contact rating (contacts gold plate on silver)	1 mA...6 A, DC 5 V...AC 250 V <input type="checkbox"/>	1 mA...6 A, DC 5 V...AC 250 V <input type="checkbox"/>
Auxiliary switch switching points	3° < / 87° < (referred to 0...90° <)	3° < / 87° < (referred to 0...90° <)
Auxiliary switch tolerance	±2	±2
Connecting cable motor	1 m, 3 x 0.75 mm ² (halogen-free)	1 m, 3 x 0.75 mm ² (halogen-free)
Connecting cable auxiliary switch	1 m, 6 x 0.75 mm ² (halogen-free)	1 m, 6 x 0.75 mm ² (halogen-free)
Functional data		
Torque (nominal torque)	Min. 40 Nm @ nominal voltage	Min. 40 Nm @ nominal voltage
Direction of rotation	Selected by mounting L/R	Selected by mounting L/R
Angle of rotation	Max. 100° < (incl. 5° < mechanical overrun on each side)	Max. 100° < (incl. 5° < mechanical overrun on each side)
Running time	<60 s for 90° <	<60 s for 90° <
Sound power level	Max. 62 dB(A)	Max. 62 dB(A)
Damper rotation BE24	Form-fit 14 mm	Form-fit 14 mm
Damper rotation BE24-12	Form fit 12 mm	Form fit 12 mm
Service life	At least 10,000 cycles	At least 10,000 cycles
Safety		
Protection class	III Safety extra-low voltage	II totally insulated <input type="checkbox"/>
Degree of protection	IP54 in all mounting positions	IP54 in all mounting positions
EMC/LVD	CE according to 89/336/EEC, 92/31/EEC, 93/68/EEC	CE according to 2004/108/EC CE according to 2006/95/EC
Ambient temperature range normal duty	-30° ... +50°C	-30° ... +50°C
Weight		
Weight	Approx. 2.7 kg	Approx. 2.7 kg

Grille Details

The grille offers a discrete appearance which limits visibility to the rear mounted damper whilst providing good free area, satisfying both engineering and architectural requirements.

Manufactured from 6063 T6 grade aluminium extrusion, the individual grille cores blades are supported with integral aluminium tubes. The grille core is mounted in an aluminium extruded frame with mitred corners.

The grille is fitted to the damper with the supplied colour matched M4x16mm fixing screws. These simply pass through the grille blades and screw guides, locating into the mating threaded damper bracket behind.

Use the purpose designed Allen key supplied to fit the screws to prevent damage.

The grille is an integral part of the LD & LDN damper and has been tested as an assembled unit and is CE certified as an assembly.

The fitting of alternative grilles within 200mm of the damper would invalidate the CE mark.

Grille Cross Section

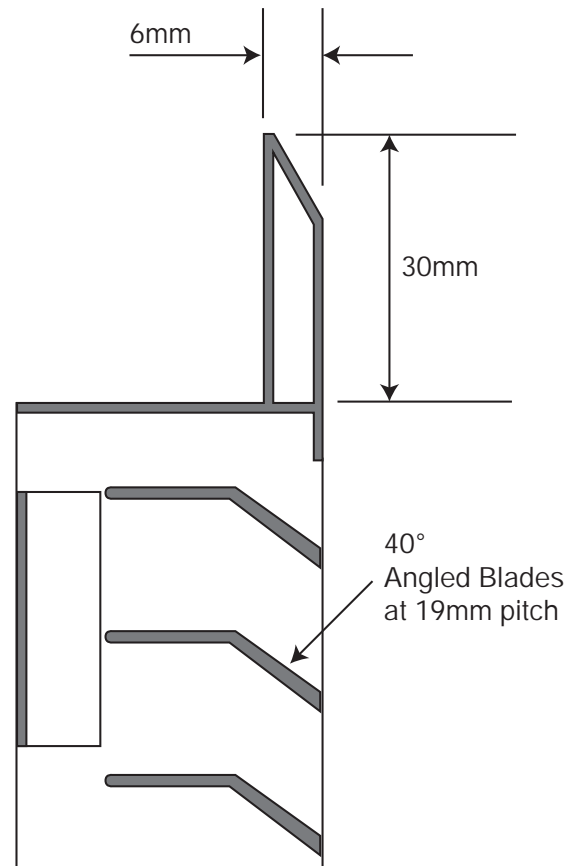

Grille Fixing Detail

Self coloured 4x 16mm fixing screw passes through the grille utilising the special provided Allen Key.

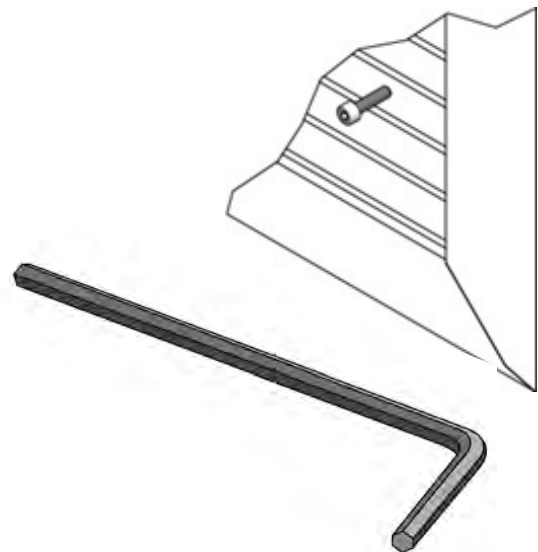

Fixing bracket with elongated slot for easy alignment.

Corner grille fixing guides

Intermediate grille fixing guides

Grille blades supported via continuous vertical rods.



LD and LDN Series

Lobby Dampers



LDN - SIZE - BE24 - GRILLE - RAL9010

Model:
LD Lobby Damper - Mechanical Vent
LDN Lobby Damper - Natural Vent

Structural Opening Size:
 Width x Height

Grille Colour:
RAL9010 White Standard
SPECIAL Please specify

Actuator Options:
BE24 Open/Closed
BE230 Open/Closed

Other Air, Fire and Smoke Control Products in the BSB Range:



For full details of the complete BSB Product Range, please refer to our individual product brochures, sales office or website.



BSB Engineering Services Limited

Unit 56, Trinity Trade Centre, Mill Way, Sittingbourne, Kent ME10 2PD, UK • Tel: +44 (0)1795 422609

For purchase orders and order related enquiries, please email: orders@bsb-dampers.co.uk

For pricing, technical and general enquiries, please email: enquiries@bsb-dampers.co.uk

Website: www.bsb-dampers.co.uk • A member of the Maico group

BSB Engineering Services Ltd. reserves the right to modify or withdraw any specification without prior notice that may result from continuous product development. The information contained within this brochure is correct at the time of going to press. (LD/LDN-04-2022)

