

WALL COWL

ELTA

» **Select** models available for next day delivery



WALL COWL

Overview

- Protects fan openings prevailing weather conditions
- Minimises resistance to airflow
- Manufactured from GRP - colour (goose wing grey) impregnated into gel coat
- Complete with integral bird screen (galvanised mesh)



Product Code	A	B	C	Grille Area m ²	Weight kg
SWC25/31	500	410	325	0.088	2
SWC35/40	610	510	390	0.140	3
SWC45/50	755	645	470	0.217	7
SWC56/63	935	815	555	0.345	10

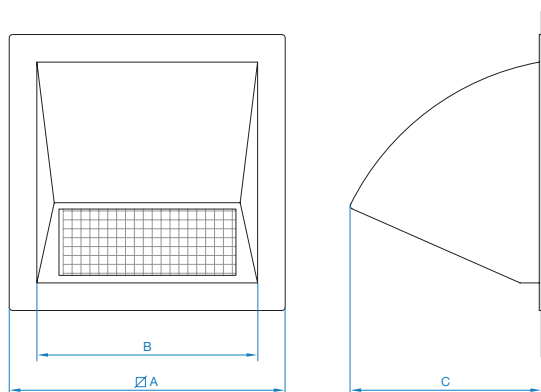

Dimensions are in mm.

WALL COWL

Cowl Pressure Drop Curve

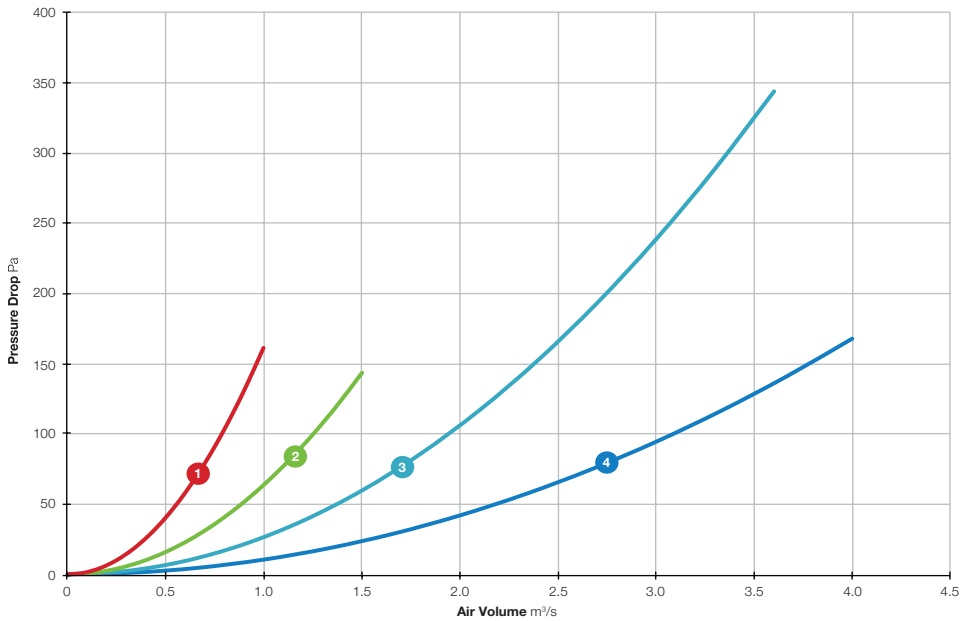

- 1 SWC25/31
- 2 SWC35/40
- 3 SWC45/50
- 4 SWC56/63

Determine pressure loss against required flow rate and add pressure loss value to system design pressure, verify that fan selection can accommodate extra pressure loss.
Original design: flow rate (m³/s) and pressure (Pa), with cowl becomes flow rate (m³/s) and (pressure (Pa) + pressure loss (Pa) from curve).

Tel **+44 (0) 1384 275800**
Email **info@eltauk.com**
eltauk.com

SWC-03-2018 Issue A

