

Installation instruction Control Panel for Fire Ventilation

SVM Micro 24V-4A



Fire ventilation

Comfort ventilation

- Can be connected to a fire switch.
- Has deep discharge protection.
- Can be connected externally and can control the operation of for example gates, doors or curtains, as well as opening systems.
- Automatic reset after alarm mode.
- Potential free contact can give alarm and fail indication.

Address of installation

Name:

Address:

Phone no.:

Contact person:

Date of installation:

Installation

Number of control panels and type (ex. SVM Micro 24V-4A):

Number of fire ventilation groups:

Type of opening system:

Type of opening system:

Type of opening system:

External controls (AFA-CCS):

Comfort control:

Wind- and rain sensor:

230V power supply from group:

Table of contents

Address of installation / Description of installation	2
General description	4
Safety rules during installation and operation	4
Explosion danger.....	5
Installation.....	5
Yearly legal requirement of maintenance and control	5
Batteries	5
Connection to motor- (actuator) outputs and line monitoring	6
Current limiter type LIP.....	7
Operation and connection of fire switches.....	8
Auto reset.....	9
Connection of smoke-/heat detectors.....	9
Comfort ventilation - connection and settings	9
Diagram control panel and connections	10-11
External LEDs on the front panel (LED board).....	12
Internal LED indication on the main board	12
Fuse specifications	12
Complete jumper settings	13
Connection of more control panels to one fire group (bus connection) N/A.....	14
Connection of weather sensor / Close all function	15
External signal transfer, connection of AFA systems and other systems	15
Special functions.....	16
Fireman's Priority Switch N/A.....	16
Cable sizes	17
Part no. and accessories	18
CE Declaration of conformity	19
Technical specifications.	20

Rev 0.02 23.09.2024

Manufacturer:

Actulux A/S
Porsborgparken 35
9530 Stoevring
Denmark

Tlf.: +45 98 57 40 90
e-mail: info@actulux.com
www.actulux.com

General description

The control panel can be used for electrical opening of e.g. skylights, smoke hatches or similar in connection with fire- and comfort ventilation.

The control panel has different inputs with line monitoring which can be activated by e.g. fire switches, smoke detectors, heat detectors, AFA systems and CCS systems.

For control of the indoor climate (comfort ventilation) manual switches, weekly timer, room thermostat and outdoor weather sensors can be connected.

By means of LEDs in the the front panel the control indicates the operating condition (ok operation and error- and alarm condition), just as it by means of the built-in potential free relay contacts can relay operating information about ok operation and error- and alarm condition to other systems in the building.

The polarity of the motor supply is reversed when opening or closing.

The control panel has built-in 72 hours battery back-up.

By a unique bus system consisting of a 4 wire cable the control panels can be mutually connected so that up to 35 control panels can be connected and operate as an integrated system.

If the temperature in the control panel exceeds 75 °C, the control panel will enter ALARM condition.

Connection of cables to the in- and outputs of the control panel is described in the connection drawing on page 10-11.

A more detailed connection to the individual in- and outputs is described in the individual sections in this manual. Selection of cable sizes on page 17.

By means of jumpers and dip switches the control panel has different setting possibilities for in- and outputs. These settings are indicated in a complete table (please see section with jumper settings on page 13).

Examples of types of openings systems and the max. power consumption which can be connected to the control panel:

Type:	24V power supply:
SA Power Single	4A
SA Power Double	8A (2x4A)
SA Power Large	8A
SA Power Mini	2.5A
Others	See specification of max. power consumption on the opening system

Safety rules during installation and operation

The control panel may only be installed and maintained by personnel authorized for installation of automatic electrical fire ventilation equipment.

Explosion danger

The control panel is supplied with back-up batteries, which contain large amounts of energy which can be released as explosion in case of wrong handling - the following safety rules must therefore always be observed:

- Never short-circuit a back-up battery.
- Do not use external chargers on installed batteries. If unauthorized chargers are used explosive gasses can be released from the battery.
- Do not drop back-up batteries as strong acids can be released if they are broken.

Installation

The control panel can weigh up to 7 kg and must be installed on a stable wall. The mounting holes for wall mounting are placed on the metal plate underneath the plastic lid. When mounting several control panels side by side, the distance between them must be min. 30 mm.

All cables are connected according to the drawing on page 10-11 and are dimensioned according to table page 17. Keep in mind that the operating voltage from the control panel is 24V and that the max. voltage drop is 15% which demands correct cable dimension according to table on page 17.

If cables are passed through the back plate, the edges of the plate must be lined with edge bands to protect the cables.

Please be aware that it often may be required (in order to keep the demands on the CE marking of the complete installation or another law) that the control panel is supplied with 230VAC from separate powerline with its own ground error circuit interrupter, and that a repair interrupter is mounted on the motor line.

After connection the control panel must charge the batteries min. 12 hours before complete testing. Remember to fill out site specific data and sign.

Yearly requirement of maintenance and control (authorized)

The functions of the control panel and the opening system must be tested by authorized personnel at least once a year. The control panel informs when the maintenance should be done. Then the external LEDs on the front panel are running. The control panel and opening system are of course still full operating. Please call a service technician at your earliest convenience in order to carry out the maintenance and to test the control and opening system, in order to prepare it for another year of operation. The legal requirements for this must be observed and the testing and control must as a minimum include the following:

- Control that all opening systems move to full opening when the fire function is activated - should not be carried out if the wind is more than 6 m/sec. as there might be a risk that the opening system cannot close automatically.
- Control of the batteries. If the batteries are replaced it is important to use the same type as the batteries are carefully chosen to be able to deliver the current, for which the control is specified.
- Control of in- and outputs on the control.
- Control of fire switches and smoke- and heat detectors.

Batteries

The batteries should be replaced as required, however at least every third year!
Use the same brand.

In order to protect the batteries from discharging, this means that during the installation phase the panel will automatically switch off at a battery voltage of 17V and switch on again at 18V.

If the batteries have been discharged below 19V, the battery fault led will flash rapidly. This indicates that the batteries are low, and can be reset by setting Service on/off.

To avoid a false indication, it is advisable to start the panel on battery first.

Connection to motor- (actuator-) output and line monitoring

The actuators (motors) must be connected to the actuator output on the output terminals 2-3.

It is possible to connect and disconnect the line monitoring on the actuator output (the factory setting is “connected”). The cables to the actuators can be connected in series or parallel or a combination of these (please see drawing with examples or connection diagram on the mid pages).

It is important to keep the right polarity of the cables - The actuators must always be connected through a current limiter, e.g. the Actulux LIP or similar.

Cable monitoring (line monitoring) on the motor output

The control is equipped with 3 possible settings for cable monitoring (line monitoring), which can be configured by means of jumper J2.

Jumper J2 mounted in pos. »Motor line«

Line monitoring between terminal 2-3.

Jumper J3 (actuator output) is set according to the number of termination resistors (27 K Ω) to be detected – 1 to max. 4 lines can be detected by moving jumper J3 – this means that the cable installation between the control panel and the actuators can be established in star connection (cable connection from e.g. skylight 1, further to skylight 2, etc.), or parallel connection (cable connection from each skylight to the control), or a combination of these. However, as mentioned max. 4 different lines can be detected each terminated with a 27 K Ω resistor.

For SVM Micro 4A:

the max. allowed current is 4A.

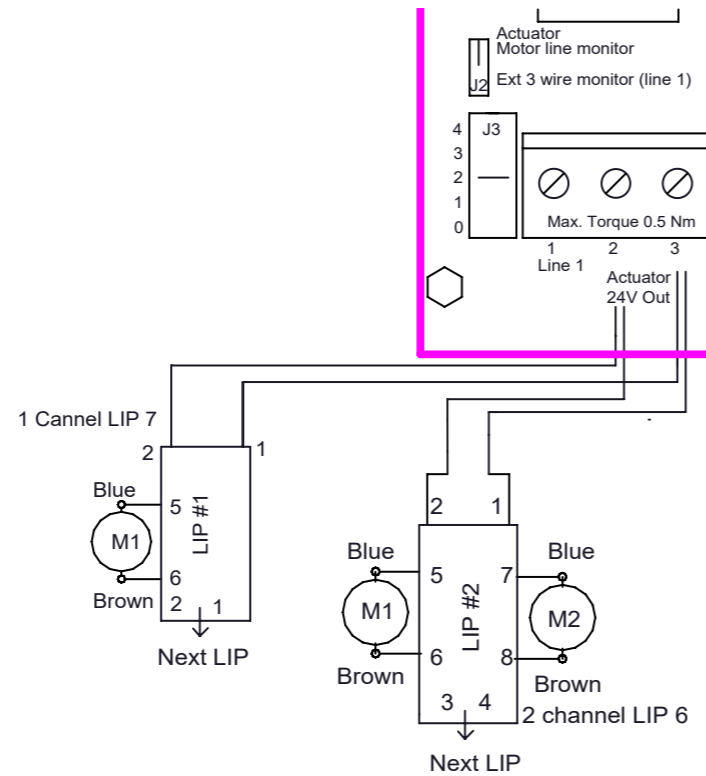

	Jumper description
J3	Number of connected 27Kohm terminal resistors for actuator output
J2	Chooses line monitoring through motor terminals 2-3 (Mot Mon) or separate wire terminals 1-3 (Ext Li Mon)
F1	Fuse 8A for actuator output

Jumper J2 in pos. »Ext 3 wire«.

Line monitoring between terminal 1-3:

With jumper J3 (actuator output) it is chosen, how many lines (number of 27 K Ω) you wish to detect - the same way as the motor line.

This setting demands 3 wire cable from motor output to motor.

No line monitoring

To disable line monitoring set jumper J3 to position 0.

NOTE: it is recommended that line monitoring should always be activated wherever possible.

LED 4 indicates if there is any fail on the actuator output. Steady light if wire is broken.

“Flashing fast” in case output is connected to earth. Flashing slow if output is shorted.

NOTE: When Flashing RESET or close is not possible

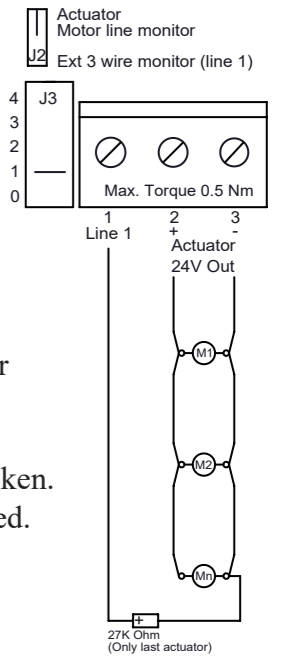

Current limiter type LIP function and setting (if mounted)

The current limiter type LIP (mounted on the opening system) is used as current limiter between the 24V/48VDC supply and 1 or 2 actuators. When the adjusted current limit is reached, the speed of the actuators is reduced. When the max. power on the actuator is exceeded, the actuator stops. On the 24V /48V types (LIP5, LIP6 or LIP7) max. 3 times overload cut outs in the same direction is allowed. After that it will not be possible to run in this direction again, before the motor has run in the opposite direction. This in order to protect the actuator gear mechanism.

Please note that when opening, the red LED in the LIP must light. This indicates that polarity to actuator is correct.

LIP settings

Set according to the type label on the traverse (opening system).

Operation and connection of Manual Control Points (BVT or MCP)

The Manual Control Point will generally contain the following:

- Breakable glass window and red control button is activated by pressure - this puts the control panel in ALARM condition, by which the motor output is activated (for normal service and testing the lid can be opened with a key).
- RESET button which brings the control panel out of the alarm condition and starts the closing sequence for about 180 seconds. Please note that RESET does not cancel errors on the system, e.g. line errors etc. These must be found and corrected.
- RED LED indicates that the control panel is in ALARM condition and that the motor output either is or has been activated.
- YELLOW LED indicates faults on the system - please call for a service technician.
- GREEN LED indicates that the system is in normal operation condition without errors.

CONNECTION of the fire switch is made as shown on the drawing. The installation with fire switches must be terminated with a 10 KΩ or 27 KΩ resistor in the last switch in order to establish the line monitoring correctly – this can either be done by moving the factory mounted resistor from the terminal strip to the last fire switch or connect **jumper J1** in the fire switch type BVT is mounted (by this a 10 KΩ resistor is also connected) or K10 in type MCP. Jumper K5 (only integrated in MCP) has no function. All Jumpers are factory fitted on delivery if a fire pressure type BVT or MCP is used.

* If no fire pressure is used, the 10 kΩ resistor must remain in the control center.

By means of DIP switches the control panel has different possibilities of settings for the input to the fire switch:

DIP 1 (Conf. firesw.):

On = ALARM condition from 500-3 KΩ, (indication of line error by direct short circuit or open circuit).

Off = ALARM condition from 0-3 KΩ (indication of line error by open circuit).

DIP 2 (Failsafe):

On = Any line error on fire switch or smoke detector puts the control panel in ALARM condition. This function can be used if cables to fire switches and smoke detectors are not fireproof.

Off = An error condition does not report ALARM condition.

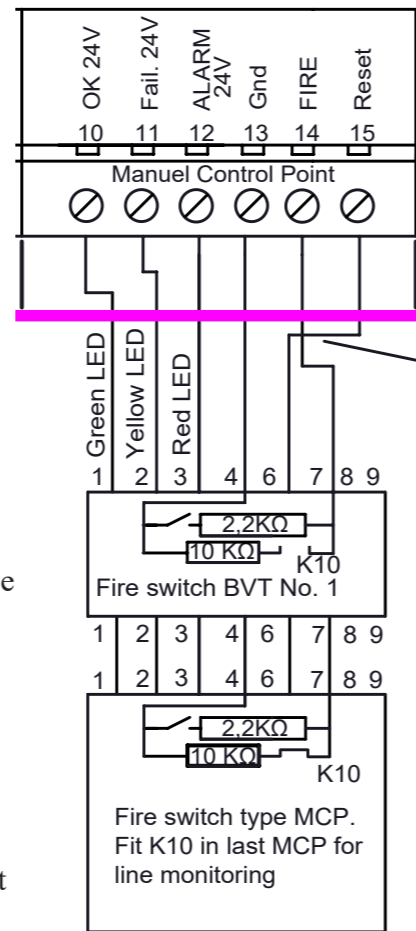
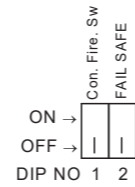

BVT

- 1 green LED OK (lights when OK and while closing)
- 2 yellow LED (lights on error)
- 3 red LED alarm (emergency opening)
- 4 GND (-)
- 5 not used
- 6 fire switch reset
- 7 fire switch emergency opening
- Jumper J1 must only be set in the last or only fire switch

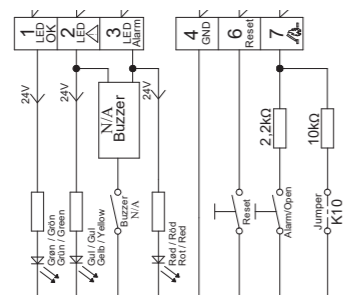

MCP

- 1 green LED OK (lights when OK and while closing)
- 2 yellow LED (lights on error)
- 3 red LED alarm (emergency opening)
- 4 GND (-)
- 6 fire switch reset
- 7 fire switch emergency opening
- 8 no application
- 9 Open
- Jumper K10 may only be set in the last or only fire switch

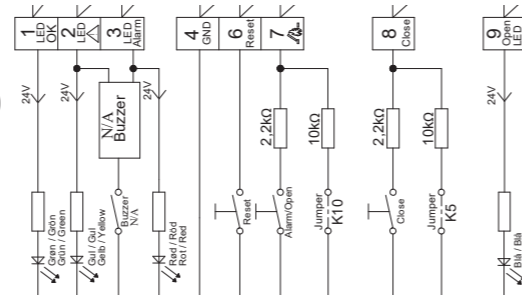

Auto reset

When setting OPTION(DIP8) On, an automatic reset is performed 2 seconds after the fire signal is removed. (From software version V1.005)

Connection of smoke-/heat detectors

Smoke- and heat detectors are connected as shown.

Line monitoring: Correct line monitoring can only be guaranteed with detectors delivered from the supplier. Other detectors may have different internal resistances and stand by power consumption.

Comfort ventilation – Connection and settings

The motor output can be controlled separately with a comfort switch.

For comfort ventilation there are the following possibilities:

Potentiometer in Puls pos.:

It is possible to press the »up« button 3 times, which each gives 6 seconds of opening time - after that nothing happens – Continuous »up« signal gives 3x6 sec.=18 sec. - One press on »down« closes the actuator completely for a period which is 18 sec. longer than the complete opening time - In order to avoid »actuator pumping« max. 3 successive closing attempts will be allowed.

Potentiometer in Const. pos.:

As long as »up« signal or »down« signal are given, the actuators are running

Potentiometer in Puls variable pos.:

The time on the above mentioned pulse opening can be adjusted from 0-60 sec. on the potentiometre.

When moving the potentiometer into the different positions the LED batt low will flash for about 4 sec. to indicate when in puls mode. LED line fail flashes 4 sec. when in constant and AC fail flashes when in puls variable.

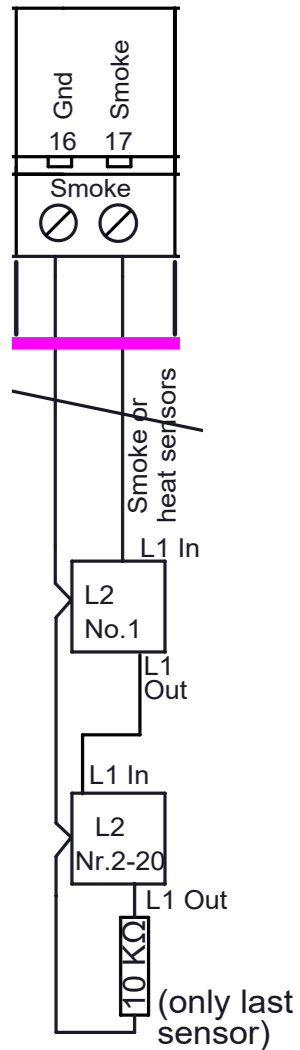
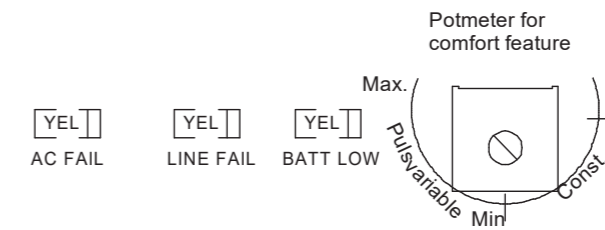

Room thermostats, weekly timers, CCS and other external control equipment for comfort ventilation can be connected on the input of the comfort control.

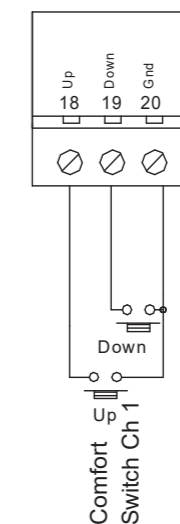

Connection SVM Micro 24V - 4A

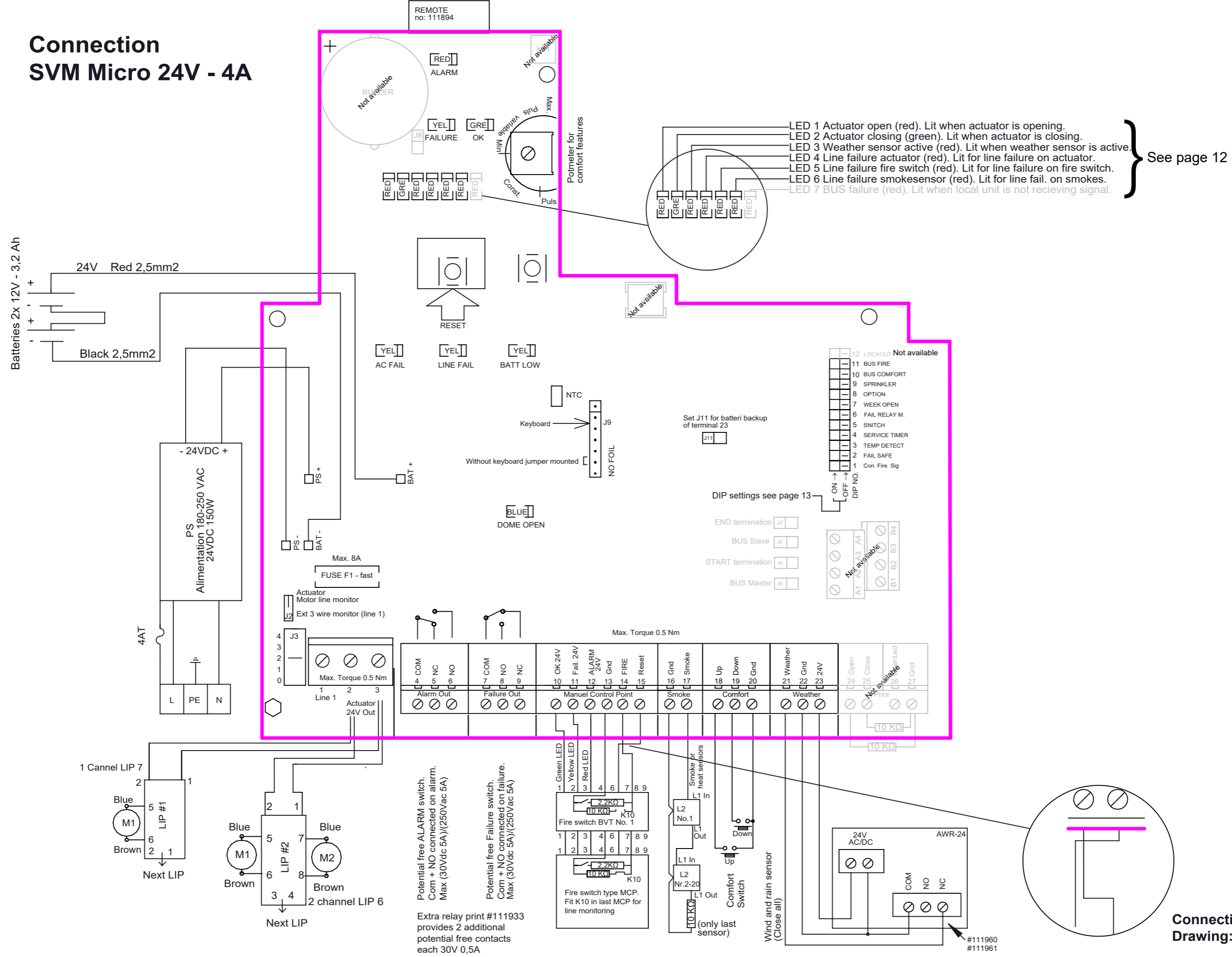

See page 12

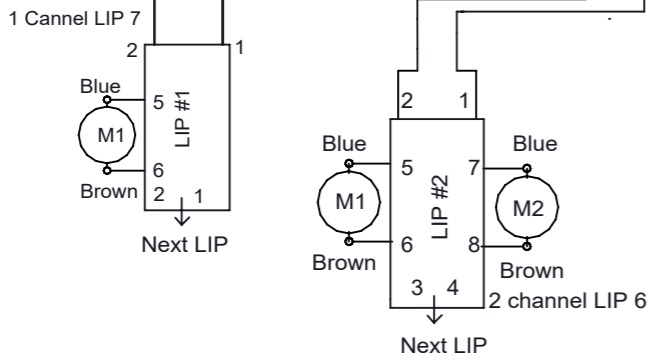

Potential free ALARM switch. Com + NO connected on alarm. Max (30Vdc 5A)/(250Vac 5A)





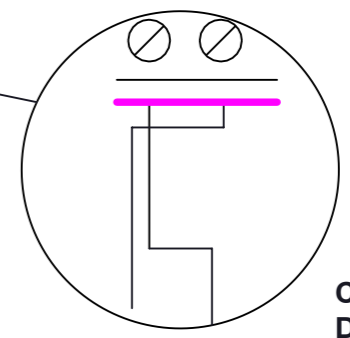
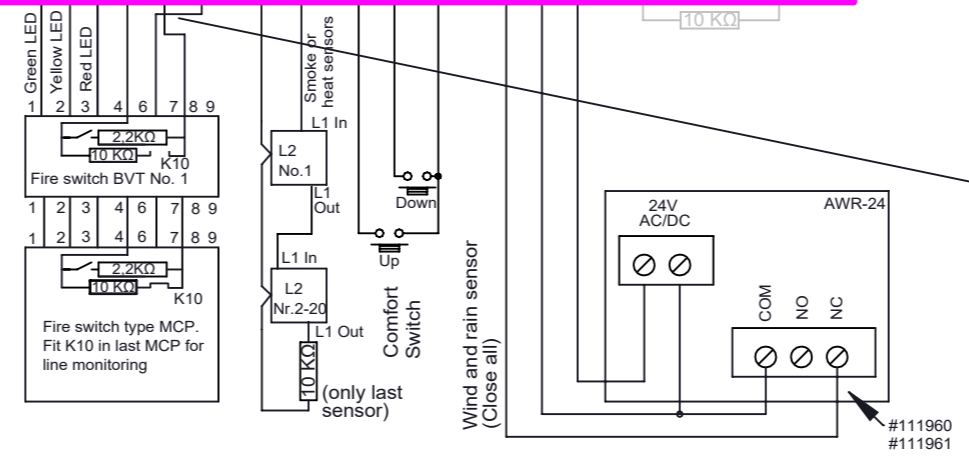

Potential free Failure switch. Com + NO connected on failure. Max (30Vdc 5A)/(250Vac 5A)

Extra relay print #111933 provides 2 additional potential free contacts each 30V 0,5A



Connection diagram SVM Micro Drawing: 211902_A

LEDs on main board and front panel

LED/colour	Symbol	Operation possibilities for:	Alarm/ fire	Comfort operation
LD1/red		Actuator open (red). Lights when actuator opens		
LD2/green		Actuator close (green). Lights when actuator closes		
LD3/red		Weather sensor active (red). Lights when weather sensor is active	Yes	No
LD4/red		Line error on actuator (red). Lights when actuator has open circuit, flashes at earth fail or when short circuit occur. It is not possible to RESET or close with actuator output (see page 7)	Yes	No
LD5/red		Line error on fire switch (red). Lights when fire switch has line error, flashes when Fireman's Priority Switch has line error	Yes	Only close
LD6/red		Line error on smoke detector (red). Lights when smoke detector has line error, flashes at temperatures above 75 °C	Yes	Only close
LD7/red		Bus error (red). Lights when BUS signal from other controls is missing. Only relevant if J4-J7 is mounted.	Yes	Only close
Green Board + Front	OK	lights if everything is ok switched off by local error on this control flashes by error message from other controls received by bus	Yes	Yes
Yellow Board + Front		Fault lights by local error on this control or by error message from other controls received by bus	Yes	Only close
*Yellow Board + Front		Line error flashes by local error on this control and if the ribbon cable or jumper is not mounted on J9, or by error message from other controls received by bus	Yes	Only close
*Yellow Board + Front		AC error flashes by local error on this control or by error message from other controls received by bus	Yes	Only close
Red Board + Front		Alarm lights red constantly	Yes	No
*Yellow Board + Front		DC error flashes at normal speed (1 Hz) by local battery error on this control or by error message from other controls received by bus flashes at high speed (10 Hz) by battery voltage below 19V. Reset by DIP 4: OFF/ON		
Blue Board + Front		Lights blue constantly in open condition (when windows are open) flashes when actuator is moving up and down		
Yellow / Blue		flashes when internal memory fail is detected	Yes	Yes
Lights with*		Time for yearly service - please call for supplier (flashes fast)	Yes	Yes

Fuse specifications

Fuse value	Placement	24V
F1 8A fast acting fuse		1 pcs. for 24V motor output

Complete jumper settings for SVM Micro PCB

	Text on board	Factory mounted	Mounted / ON function	Dismounted / OFF function
DIP 1	Conf. Fireswitch	No	Fire switch active from 500-3 KΩ. A short circuit of the smoke detector input will generate a line error	Fire switch active from 0-3 KΩ. A short circuit of the smoke detector input will generate alarm
DIP 2	Failsafe	No	Line error on fire switch or detector puts the control in alarm	Normal mode
DIP 3	Temp. Detekt	No	Line error on motor line (upper resistor area) = alarm	Normal mode
DIP 4	Ser	Yes	Active	Inactive
DIP 5	Snitch	No	LED's "remember" errors (line errors, AC/Batt. error, bus error). The LED's can only be switched off/reset again by setting dip switch off	Normal mode
DIP 6	Fail Relay	No	Failure relay works as indication that skylight is open	Normal mode (works as failure relay)
DIP 7	Week open	No	Weekly open (2 sec.) /close (5 sec.) cycle activated	Weekly open/close not activated
DIP 8	Option	No	Auto reset (see page 9)	Normal mode
DIP 9	Sprinkler	No	Motor output closes by active detector (opens by activating the fire switch)	Normal mode - motor output opens by active detectors or fire switches
DIP 10	Bus comfort	No	The control reacts on comfort signal via bus activity	The control does not react on comfort signals via bus activity // NB! Always reaction on weather signal and failures via bus activity and own comfort signal
DIP 11	Bus fire	No	The control reacts on alarm signal via bus activity	The control does not react on alarm signal via bus activity //NB! Always reaction on weather signal and failures via bus activity and own alarm signal (detector or fire switch)
DIP 12	Lock-Out Mode - N/A	No	Slaves can enter Lock-Out Mode - N/A	Normal mode
J1	J1	Yes	Internal Buzzer ON - N/A	Internal Buzzer OFF - N/A
J3 (motor)	0 - 1 - 2 - 3 - 4	Pos. 1	Connect according to number of 27KΩ terminal resistors on actuator	No line monitoring
J2 (motor)	Mot Mon act.	Yes	2 wire line monitoring via 27KΩ terminal 2-3	No line monitoring
	Ext Li Mon act.	No	3 wire line monitoring with direct motor connection actuator	
J4(Bus)	Start term.	No	First control panel in the bus network	See section concerning connection of controls panels in bus connection, page 14
J5(Bus)	+ Master	No		
J6(Bus)	Slave	No	Middle and last control panel in the bus network	
J7(Bus)	End term.	No	Last control panel in the bus network	
J9	FOIL	Yes in Basic	Line monitoring of front cabinet	Line error flashes
J11	BatSup->Ø23	No	Battery backup of terminal 23	Terminal 23 only AC supplied

Others: Reset time = 180 sec. closing // Cut-off motor output and loading after 360 sec. // Comf. var (potentiometer): 1-60 sec.

Connection of more controls to one fire group (bus connection) N/A

Connection of weather sensor / Close all function

A weather sensor can be connected to the control panel.
 The weather sensor is adjusted according to the instructions.
 Actuators should be closed when the wind is above 6 m/s.
 LED 3 on the main board indicates active weather sensor - lights as long as input is active.

As long as the weather sensor is active, motor inputs cannot be opened with comfort switches.

The weather sensor closes on all controls which are connected through bus connection.

On the input to weather station a weekly timer can be connected which makes sure that everything is closed, e.g. by end of a working day.

Power Supply to terminal 22 and 23 is only AC supplied as standard.
 If battery backup is needed, then mount J11 .

NOTE: Be aware of standby time due to current consumption.

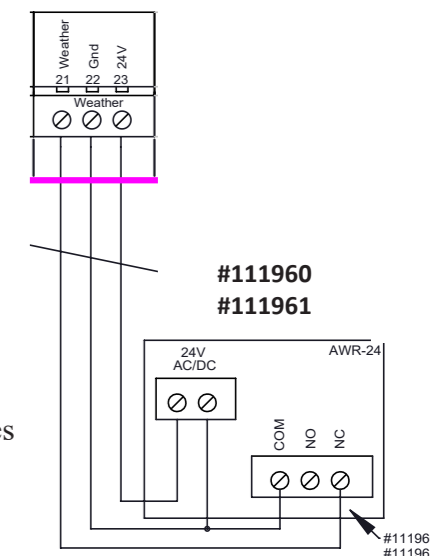

External signal output, connection to Fire Alarm Panel and other control systems

The control panel can forward alarm condition to external connected systems by means of potential free contacts on the terminals 4 (com), 5(NC) and 6(NO).

The control panel can forward failure condition to external connected systems by means of potential free contacts on the terminals 7 (com), 8(NO) and 9(NC).

Alarm and error contacts work parallel on all controls connected with bus connection.

DIP6 (fail relay):

On = Fail relay changes function to indicate open/closed window.

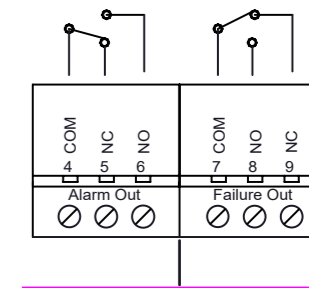

Potential free ALARM switch.
 Com + NO connected on alarm.
 Max (30Vdc 5A)/(250Vac 5A)

Potential free Failure switch.
 Com + NO connected on failure.
 Max (30Vdc 5A)/(250Vac 5A)

Extra relay print #111933 provides 2 additional potential free contacts each 30V 0,5A

How to make a connection from a Fire Alarm Panel

The control panel can receive potential free zero volt alarm signals from e.g. AFA systems on the input to fire switch or smoke-/heat detector Terminal 16 and 17.

– Line monitoring resistor must be fitted on the contact in the AFA system

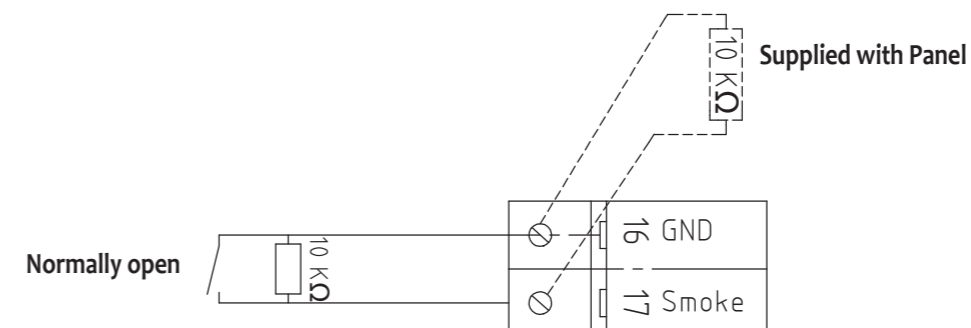

Special functions

Sprinkler function:

DIP 9 On - a special function comes in use where sprinkler systems are installed. With this function activated, the actuator output closes, if smoke-/heat detector input is activated.

If the fire switch is activated, the actuator output opens.

Weekly open/close:

DIP 7 On - the motor output opens shortly (3 seconds) once a week and closes immediately after - This function is used to give the right tension on the packing of the skylights to keep them watertight.

Function of heat detector in LIP:

DIP 3 On - a heat detector 70-100 °C can be mounted in each LIP. If the temperatur is exceeded, the control panel goes into alarm and the opening system is opening.

Fireman's Priority Switch - N/A

Cable sizes

It is very important to use the correct cable types and sizes to make sure that the fire ventilation system meets the standards and works correct in an emergency.

The two most important factors are the ability of the cables to resist heat and to make sure that the voltage drop in the cables to the actuators do not exceed 15 % at full load on the fire ventilation hatches.

Fire resistant cables according to IEC 60331 must be used for the following functions:

Opening systems with actuators 24V	2 wires, see diagramme (3 wires by external line surveillance)	Max. cable length
Fire switch 24V	Min. 6 x 0.5 mm ² (0.8 mm)	100 m*
Smoke detector 24V	Min. 2 x 0.5 mm ² (0.8 mm)	100 m*
Heat detector	Min. 2 x 0.5 mm ² (0.8 mm)	100 m*
Total length of bus cable	4 x 0.5 mm ² (0.8 mm)	300 m*

* For cable lengths longer than 100m, properly closed shielded cables must be used.

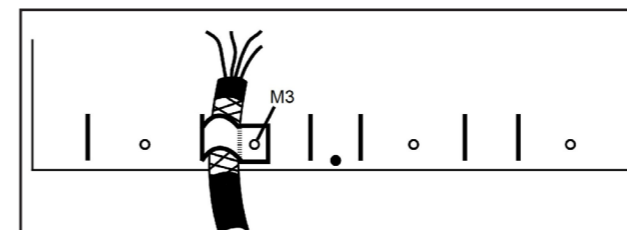

Normal cables can be used for the following functions:

Supply for control 230VAC	e.g. 3 x 1.5 mm ² PVIK-J
Comfort ventilation button 24V	Min. 3 x 0.5 mm ²
Wind- and rain sensor 24V	Min. 4 x 0.5 mm ²

Table for SVM Micro 24V-4A allowed voltage drop 15% = 3.6V

Power consumption per group in ampere	Cable cross section and amount of cores						
	2x1.5 mm ²	2x2.5 mm ²	4x1.5 mm ² (2x1.5+2x1.5)	4x2.5 mm ² (2x2.5+2x2.5)	2x6 mm ²	5x2.5 mm ² (2x2.5+3x2.5)	2x10 mm ²
2	74 m	12 3m	148 m	246 m	295 m	307 m	492 m
4	37 m	61 m	74 m	122 m	148 m	154 m	244 m
6	25 m	41 m	50 m	82 m	98 m	102 m	164 m
8	18 m	31 m	36 m	62 m	74 m	77 m	124 m

Part no. and accessories

Spare parts no.	Name of part	Description
211062	Power supply 150W 27VDC MW	Power supply 230VAC/27VDC for 5A control
211210	Circuit breaker 13A	Automatic fuse 13A / input terminal
800348	Batteri 12V/7.2Ah 151x65x98mm	Battery for 24V / 5A controls / 8A controls
111789	Fire switch/reset IP40 Actulux	Fire switch IP 40
111629	Replacement glass for BVT	Replacement glass for fire switch
111626	Fireswitch BVS in IP65 Box	Fire switch built in IP65 box
111960	Rain sensor 250VAC / 24VDC	Rain sensor closes everything when raining
111961	Wind and rain sensor 250VAC /24VDC	Wind- and rain sensor closes everything when raining or strong wind
111735	Heat detector+base 75 degree	Heat detector 75 degrees temperature activation
111741	Heat detector+base 90 degree	Heat detector 90 degrees temperature activation
111740	Smoke detector, optical	Optical smoke detector
111943	Comfort switch w/ open indication, blue diode	Comfort switch Fuga complete with housing and blue diode
111753	Comfort switch OPUS w housing	Comfort switch Opus complete with housing
111758	Comfort switch FUGA w housing	Comfort switch Fuga complete with housing
111760	Weekly timer 1 channel	Weekly timer, can e.g. close everything in the evening
111761	Comfort sw.up/down OPUS IP44	Comfort switch Opus 44 white
111767	AUTO MAN switch OPUS w housin	Switch Auto. man. OPUS white, activates room thermostat or weekly timer
111770	Room thermostat RTR w.resis.	Room thermostat for control of comfort ventilation
111933	Relay PCB extra	Board with 2x2 extra relay outputs 30V 0.5A
122200	PCB SVM EI Daughter R2	Data logger for SVM EI - N/A
121611	Programming PCB f. SVM Central	Interface for reading datalog
111892	Transmitter for Wind and Rain	Wireless weather signal together with #111894
111894	Remote control w/receiver SVM	Remote control for comfort
111980	Fireman's Priority switch w/reset N/A	Fireman's button, override the alarm and closes



(DK) YDEEVNEDEKLARATION IHT. FORORDNING NR. (EU) 305/2011
 (UK) DECLARATION OF PERFORMANCE ACCORDING TO REGULATION NO. (EU) 305/2011
 (D) LEISTUNGSERKLÄRUNG GEMÄSS DER VERORDNUNG NR. (EU) 305/2011
 (F) DECLARATION DES PERFORMANCES SELON RÈGLEMENT UE 305/2011



EN 12101-10:2005



BS EN 12101-10:2005

Produkt: Product: Produkt: Produit:	Strømforsyning Power Supply Stromversorgung Source de courant
Type/Type/Typ/Type:	SVM Micro 24V-4A SVM 24V-5A, SVM EI 24V-5A, DFM 24V-5A SVM 24V-8A, SVM EI 24V-8A, DFM 24V-8A SVM EI 24V-10A, DFM 24V-10A SV 24V-8A, 24V-24A, 24V-30A, 24V-32A SV 48V/8A, 48V-24A, 48V-30A, 48V-32A SVL 24V-15A, 24V-20A, 24V-32A, 24V-40A, 24V-50A SVL 48V-10A, 48V-15A, 48V-20A, 48V-32A, 48V-50A
Formål: Purpose: Verwendungszweck: Description du produit:	Strømforsyning til aktuator brugt i forbindelse med brandventilation Power supply for actuators used for SHEV Stromversorgung für Antriebe, die für Rauchabzug genutzt werden Asservissement pour vérins électriques
Producenten/ Manufacture/ Hersteller Usine de fabrication:	Actulux A/S, Porsborgparken 35, 9530 Stoevring, Denmark
System for attesting og kontrol af ydeevne: System for attestation and verification of performance: System zur Bescheinigung und Prüfung der Performance: Système(s) d'évaluation et de vérification de la constance des performances du produit:	SYSTEM 1

<p>Det bemyndigede organ 0402 RISE Research Institute of Sweden udførte den indledende inspektion af fabrikken og af dennes egen produktionskontrol samt løbende overvågning, vurdering og evaluering af fabrikens egen produktionskontrol til SYSTEM 1 og følgende vises:</p> <p>The notified body 0402 RISE Research Institute of Sweden made the initial inspection of factory and of factory production control, and ongoing monitoring, assessment and evaluation of factory production control to the SYSTEM 1 and the following is displayed:</p> <p>Die notifizierte Stelle 0402 RISE Research Institute of Sweden hat die Erstinspektion des Werkes und der werks-eigenen Produktionskontrolle sowie die laufenden Überwachung, Bewertung und Evaluierung der werkseigenen Produktionskontrolle nach dem SYSTEM 1 vorgenommen und Folgendes ausgestellt:</p> <p>L'organisme notifié RISE (Research Institute of Sweden) 0402 a procédé à l'inspection initiale de l'usine et à son propre contrôle de production, ainsi qu'à la surveillance, à l'appréciation et à l'évaluation continues du contrôle de production propre à l'usine pour SYSTEM 1. Les éléments suivants sont indiqués:</p>	<p>CERTIFICATE OF CONSTANCY OF PERFORMANCE NO. 0402 – CPR – SC0354-13</p>
<p>Det bemyndigede organ BSI udførte den indledende inspektion af fabrikken og af dennes egen produktionskontrol samt løbende overvågning, vurdering og evaluering af fabrikens egen produktionskontrol til SYSTEM 1 og følgende vises:</p> <p>The notified body BSI made the initial inspection of factory and of factory production control, and ongoing monitoring, assessment and evaluation of factory production control to the SYSTEM 1 and the following is displayed:</p> <p>Die notifizierte Stelle BSI hat die Erstinspektion des Werkes und der werks-eigenen Produktionskontrolle sowie die laufenden Überwachung, Bewertung und Evaluierung der werkseigenen Produktionskontrolle nach dem SYSTEM 1 vorgenommen und Folgendes ausgestellt:</p> <p>L'organisme notifié BSI a procédé à l'inspection initiale de l'usine et à son propre contrôle de production, ainsi qu'à la surveillance, à l'appréciation et à l'évaluation continues du contrôle de production propre à l'usine pour SYSTEM 1. Les éléments suivants sont indiqués:</p>	<p>CERTIFICATE OF CONSTANCY OF PERFORMANCE NO. 0086 CPR 760202</p>

Ydeevnen af produktet i overensstemmelse med punkt 1 og 2 svarer til den deklarerede ydeevne for punkt 9.
 Ansvarlig for udfærdigelse af denne ydeevnedeklaration er producenten der er henvist til i punkt 4.
 Underskrevet på vegne af fabrikanten og navnet på fabrikanten af:

The performance of the product in accordance with point 1 and 2 corresponds to the declared performance for point 9.
 Responsible for creating this declaration of performance is only the manufacturer referred to point 4.
 Signed on behalf of the manufacturer and the name of the manufacturer of:

Die Leistung des Produkts gemäß den Punkt 1 und 2 entspricht der erklärten Leistung nach Punkt 9.
 Verantwortlich für die Erstellung dieser Leistungserklärung ist allein der Hersteller gemäß Punkt 4.
 Unterzeichnet für den Hersteller und im Namen des Herstellers von:

Les performances du produit identifiées aux points \$1 et \$2 sont conformes aux performances déclarées indiquées au point \$9.
 La présente déclaration des performances est établie sous la seule responsabilité du fabricant identifié au point \$4.
 Signé au nom du fabricant et nom du fabricant de:

Stoevring 27 September 2024, Jens Buus, Managing Director

Technical specifications	SVM Micro 24V-4A
Power supply	230VAC / max. 1.5A
Output supply	24VDC
Motor outputs	1 pcs. (line detector: 1-4 lines)
Max. load	4A
Operation temperature	-15°C - +40°C
Density	IP54
Battery back-up (72h)	Yes
Batteries	2 pcs. 12V/3.2Ah
Dimensions (WxDxH)	238 x 84 x 286 mm
Weight incl. batteries	4.6 kg
Colour	White front / Black indication label
Fire groups	1 pcs. with line detect. / Max. power consumption for fire switches (LED) = 5.2mA ≈ approx. 2 fire switches
Comfort groups	1 pcs. unlimited number of comfort switches
Detector (smoke/heat) input	1 pcs. with line detection / Maximal summarized quiescent current 2.2 mA ~ 22 detectors of 100 µA per line. Minimal Alarm current 15 mA Supply voltage Minimum 18 V Maximal 29 V To Full fill the ISO21927-9 detector shall conform to ISO 7240
Weather sensor input / close all	Yes
Alarm output	Yes - potential free contact, max. 230VAC / 3A, 24VDC / 3A
Failure output	Yes - potential free contact, max. 230VAC / 3A, 24VDC / 3A
24V DC for external use	24V DC / max. 0.5A - at 230V operation
Bus communication	Yes - connection of 2-35 pcs. control panels - line detection
Visual (LED) indication in front panel	“OK” / “AC fault” / “Low battery” / “Line fault” / “Alarm” / “Comfort open” / “Fail”
Approvals / Conforms	EN12101-10:2005 approved and certified - class A (double supply) - envir. class 1 (to -15°C). According to ISO 21927-9:2012 Primary supply: 27-28.5V DC ripple 600mw P/P Secondary supply: 20-27V DC Interruption time: less than 1.5 sec.
Low Voltage Directive	2014/35/EU EN 61558-1:2006 (2nd edition), EN 61558-2-6, EN 61558-2-16 and EN 60335-1:2012 (4th edition)
EMC Directive	(2014/30/EU), EN50130-4:2011

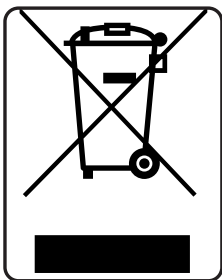

Electrical equipment, accessories and packaging must be sent for recycling for the protection of our environment!

Do not dispose electrical equipment with household waste!

According to European Guideline 2002/96 / EC on electrical waste, this must be disposed separately and sent for recycling to protect our environment.

Manufacturer:

Actulux A/S
Porsborgparken 35
9530 Stoevring
Denmark

Tel.: +45 98 57 40 90
e-mail: info@actulux.com
www.actulux.com