

SMB-2

DIN Module Enclosure

Features

- ▶ Designed to house up to 6 Hochiki DIN Modules
- ▶ Quick-release screws
- ▶ Polyurethane gasket provides IP66 protection
- ▶ Corrosion free, resistant to most alkaline and acid
- ▶ Temperature resistance to +40°C, Impact resistant, and Non-flammable
- ▶ 32 knock-outs
- ▶ Supplied with DIN Rail and fixings.

Description

Model SMB-2 is an IP66 rated, grey (RAL7035) enclosure designed for use with the Hochiki range of DIN Modules. The SMB-2 features a selection of metric knock-outs and is supplied with a transparent black lid as standard. A grey opaque lid, SMB-2(LID), is also available (sold separately).

The unit is supplied with a DIN Rail section (plus fixings) and will accept up to



six Hochiki DIN Rail Modules, side-by-side. Used in conjunction with the SMB-ADAPTOR, an adaptor plate (sold separately), this enclosure can also house any of the PCB assemblies from the Hochiki Smart-Fix Module range or the CHQ-SIM, CHQPOM or CHQ-SOM “mini” modules (see over for further details).

NOTE: For internal use only

Specification		
Ordering codes	SMB-2 - Base and transparent lid	SMB-2(LID) - Opaque lid
IP rating	IP66	n/a
Colour	Box - Grey (RAL7035) Lid - Transparent black	Grey (RAL7035)
Material	Box - Polystyrene Lid - Polycarbonate	Polycarbonate
Weight (g)	900	495
Dimensions (mm) DIN Dimensions (mm)	L 254 x W 180 x H 165 L 216 x W 35 ('top hat')	L 254 x W 180 x H 92 n/a
Knock-out configuration	Long sides	1 x M32/40 2 x M25/32 8 x M20
	Short sides	1 x M32/40 4 x M20
Suitable protection against	Weak alkali, strong alkali, alcohol, petrol, benzene, mineral oil, diesel, ammonia, vegetable oil, animal oil	
Ambient Temperature (min)	-25°C	
Ambient Temperature (max)	+40°C	

FASTENER INFORMATION:

For Mounting plate (always required) - 4 x M3 CTSK Self Tapper

For CHQ Module PCB - 2 x M4 Pan Head Screws + 2 split washers

For 'mini' CHQ - 2 x M3 CTSK Machine Screws



For further information visit our website. Hochiki reserves the right to alter the specification of its products from time to time without notice. Although every effort has been made to ensure the accuracy of the information contained in this document it is not warranted or represented by Hochiki to be a complete and up-to-date description. Check online for current version.

SMB-2

SMB-ADAPTOR - Typical Configurations

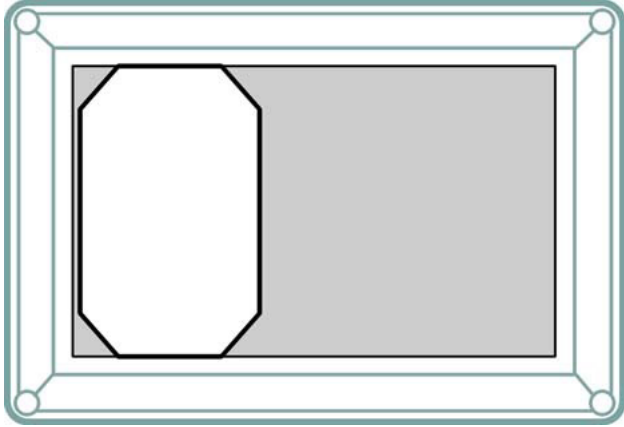

SMB-ADAPTOR with 1 CHQ-ADAPTOR (+PCB)
(fitted portrait)

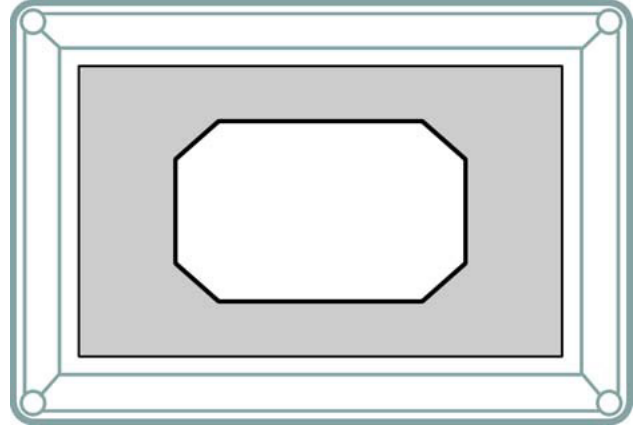

SMB-ADAPTOR with 1 CHQ-ADAPTOR (+PCB)
(fitted landscape)

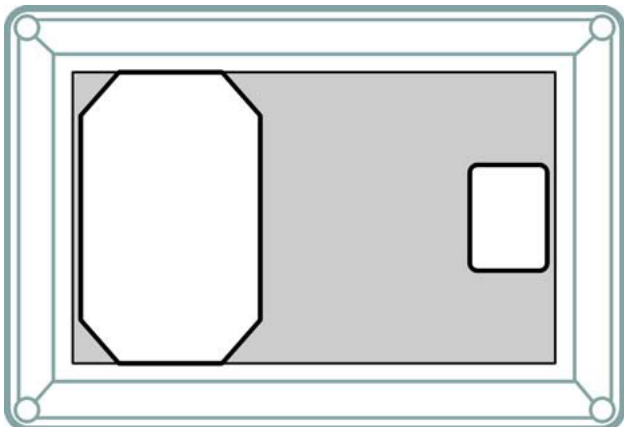

SMB-ADAPTOR with 1 CHQ-ADAPTOR (+PCB) and 1 'mini' CHQ
(for example, CHQ-POM)

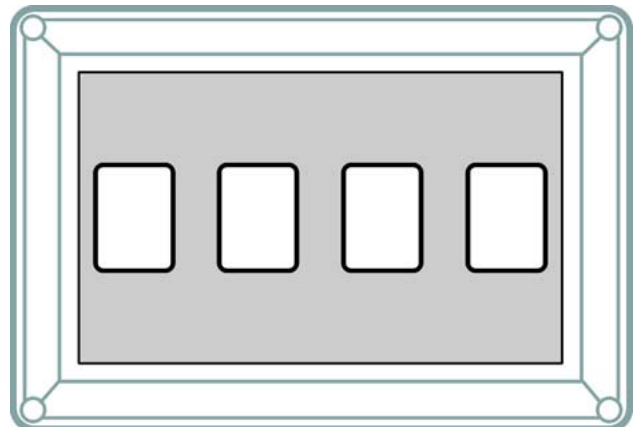

SMB-ADAPTOR with 4 'mini' CHQ
(for example, CHQ-POM)

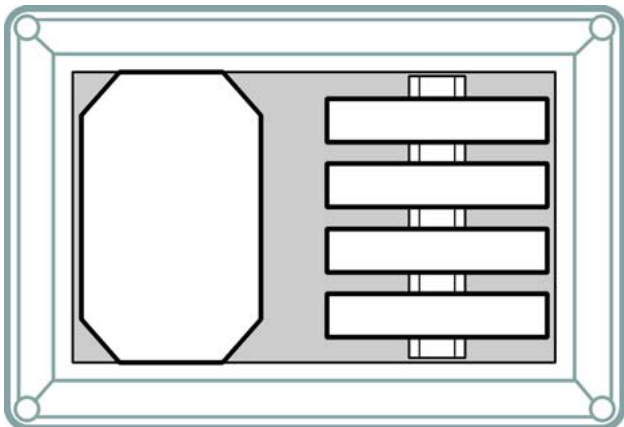

SMB-ADAPTOR with 1 CHQ-ADAPTOR (+PCB) a DIN Rail and 4 CHQ-DIN Modules

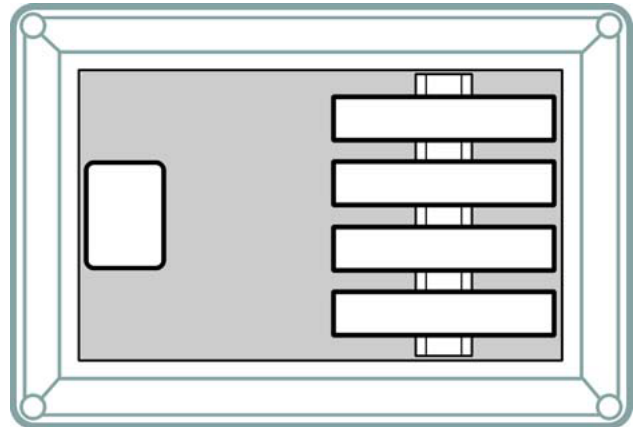

SMB-ADAPTOR with 1 'mini' CHQ
(for example, CHQ-POM), a DIN Rail and 4
CHQ-DIN Modules



For further information visit our website.
Hochiki reserves the right to alter the specification of its products from time to time without notice. Although every effort has been made to ensure the accuracy of the information contained in this document it is not warranted or represented by Hochiki to be a complete and up-to-date description. Check online for current version.

