

PIV ONE

Whole-House Positive Input Ventilation Unit

INSTALLATION, MAINTENANCE & USER GUIDE

Read this manual carefully before using the product and keep it in a safe place for reference. This product was constructed up to standard and in compliance with regulations relating to electrical equipment and must be installed by technically qualified personnel. The manufacturer assumes no responsibility for damage to persons or property resulting from failure to observe the regulations contained in this booklet.

PRECAUTIONS FOR INSTALLATION, USE & MAINTENANCE

TRANSPORT AND STORAGE

01. Do not leave the device exposed to atmospheric agents (rain, sun, snow, etc.).
02. Duct connections/duct ends must be covered during storage and installation.

INSTALLATION

03. After removing the product from its packaging, verify its conditions. Do not leave packaging within the reach of children or people with disabilities.
04. Beware of sharp edges. Use protective gloves.
05. The device should not be used as an activator for water heaters, stoves, etc., nor should it discharge into hot air/fume vent ducts deriving from any type of combustion unit or tumble dryer.
06. If the environment in which the product is installed also houses a fuel-operating device (water heater, methane stove etc., that is not a "sealed chamber" type), it is essential to ensure adequate air intake, to ensure good combustion and proper equipment operation.
07. If the supply cord is damaged, it must be replaced by the manufacturer, its service agent or similarly qualified persons in order to avoid a hazard.
08. The electrical system to which the device is connected must comply with local regulations.
09. Before connecting the product to the power supply or the power outlet, ensure that:
 - the data plate (voltage and frequency) correspond to those of the electrical mains;
 - the electrical power supply/socket is adequate for maximum device power.
10. For installation, an omnipolar switch should be incorporated in the fixed wiring, in accordance with the wiring rules, to provide a full disconnection under overvoltage category III conditions (contact opening distance equal to or greater than 3mm).
11. Ensure adequate air return into the room in compliance with existing regulations in order to ensure proper device operation.

12. Install the product so that the impeller is not accessible from the air outlet side as verified by contact with the Test Finger (test probe "B" of the norm EN61032) in compliance with the current safety regulations.

USE

13. The device should not be used for applications other than those specified in this manual.
14. This appliance can be used by children aged from 8 years and above and persons with reduced physical, sensory or mental capabilities or lack of experience and knowledge if they have been given supervision or instruction concerning use of the appliance in a safe way and understand the hazards involved. Children shall not play with the appliance.
15. Cleaning and user maintenance shall not be made by children without supervision.
16. Do not touch the appliance with wet or damp hands/feet.
17. The device is designed to intake clean air only, i.e. without grease, soot, chemical or corrosive agents, or flammable or explosive mixtures.
18. Do not use the product in the presence of flammable vapours, such as alcohol, insecticides, gasoline, etc.
19. The system should operate continuously, and only be stopped for maintenance/service.
20. Do not obstruct ducts or grilles to ensure optimum air passage.
21. Do not immerse the device or its parts in water or other liquids.
22. Operating temperature: 0°C up to +40°C.

SERVICE

23. Although the mains supply to the unit has been disconnected there is still risk for injury due to rotating parts that have not come to a complete standstill.
24. Beware of sharp edges. Use protective gloves.
25. Use original spare parts only for repairs.

01384 275771

info@eltatrade.co.uk

www.eltatrade.co.uk

INTRODUCTION

The PIV ONE is a loft mounted whole-house Positive Input Ventilation unit, designed to introduce fresh, clean and filtered air into the central hallway or landing of a dwelling without the need of a ducting system. Suitable for floor or ceiling installation.

DIMENSIONS

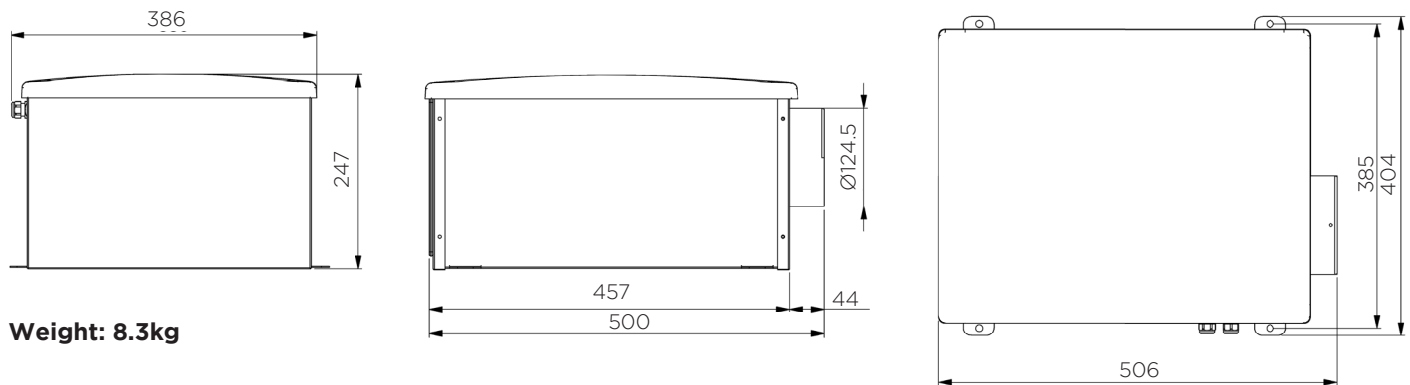

Dimensions in mm.

TRANSPORT AND STORAGE

- The appliance is delivered in one carton box.
- The appliance should be stored and transported in such a way that it is protected against physical damage that can harm spigots, casing, display etc.
- It should be covered so that dust, rain and snow cannot enter and damage the unit and its components.

WARNING: Make sure that specific warnings and cautions in the “Precautions for Installation, Use & Maintenance” are carefully read, understood and applied.

01384 275771

info@eltatrade.co.uk

www.eltatrade.co.uk

INSTALLATION

WARNING: Make sure that the mains supply to the unit is disconnected before performing any installation, service, maintenance or electrical work. The installation and service of the unit and complete ventilation system must be performed by an authorised installer and in accordance with local rules and regulations. If any abnormality in operation is detected, disconnect the device from the mains supply and contact a qualified technician immediately. **The unit must be installed according to these instructions.**

WHERE/HOW TO INSTALL

- PIV ONE units are meant for indoor installation.
- The unit should be mounted horizontally.
- Mount the unit on a flat surface (ceiling or floor).
- It is important that the unit is completely levelled before it is put into operation.
- When choosing the location, it should be kept in mind that the unit requires maintenance regularly and that the inspection panel should be easily accessible.
- Leave free space for opening the removable panel and for removal of the main components.

NOTE: Make sure that enough space is left around the unit to allow easy maintenance (access to the filters, terminal box and for removal of the inspection panel).

BOX CONTENTS

Check the contents of the box to make sure all items are present:

- 1.** Ventilation unit, **2.** Pre-Filter, **3.** Duct, **4.** Manual, **5.** Diffuser, **6.** Screws + wall plugs, **7.** 2 x Metal clamps, **8.** 2 x Mylar flap

DIFFUSER INSTALLATION

When fitting the diffuser near a smoke alarm, the blanking plates provided must be fitted to avoid blowing air over the smoke alarm and affecting its operation. If the unit is installed in a dwelling 3 storeys or above, it should be linked to a smoke alarm in such a way that power is removed from the unit if the smoke alarm is activated. Our standard diffuser is not suitable for installation in 3 storey or above homes or fire protected areas. **NOTE:** The black discs supplied with the diffuser are for not for use with the PIV unit and can be discarded.

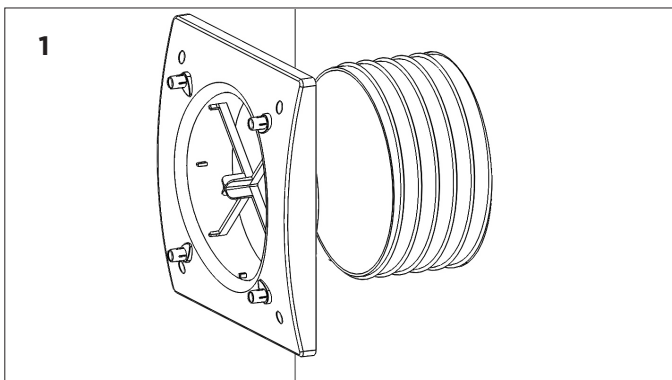

Cut an opening in the wall or ceiling for the supplied ducting, ensure the hole is wide enough to accommodate the metal clamp. Insert the ducting through the wall, leaving enough slack for the diffuser connection.

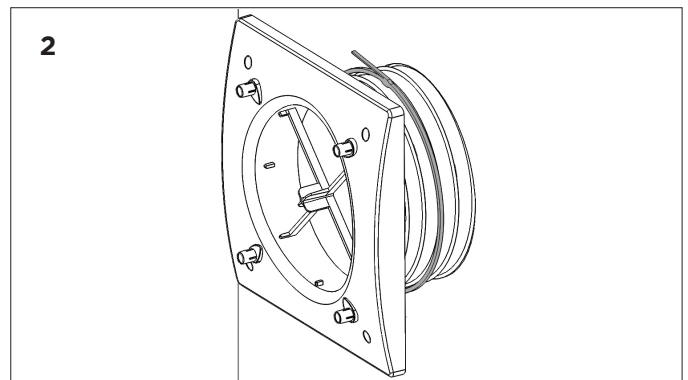

Use a metal clamp to secure the ducting to the diffuser.

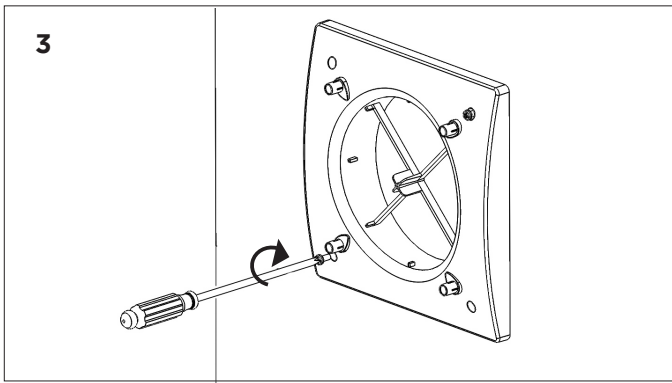

Push the clamped excess ducting back through the hole and affix the diffuser base to the wall or ceiling.

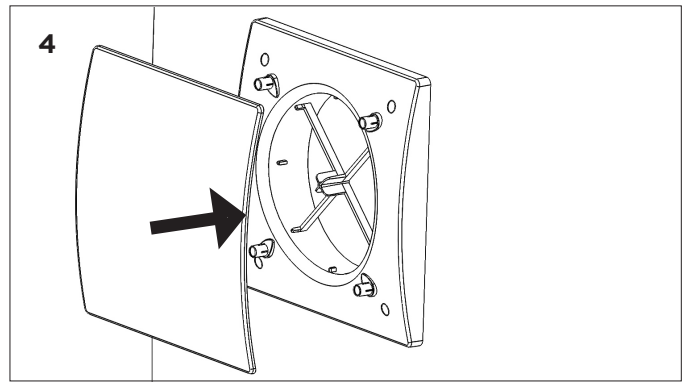

Push on the removable front cover.

CEILING INSTALLATION

The unit must be installed in the following position.

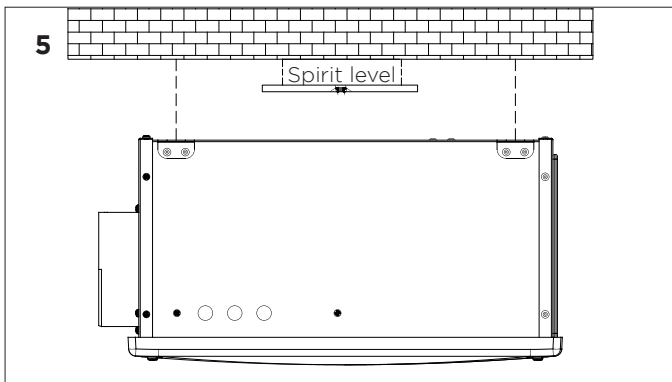

Prepare the surface where the unit is to be mounted. Make sure that the surface is flat, levelled and that it supports the weight of the unit. Perform the installation in accordance with local rules and regulations.

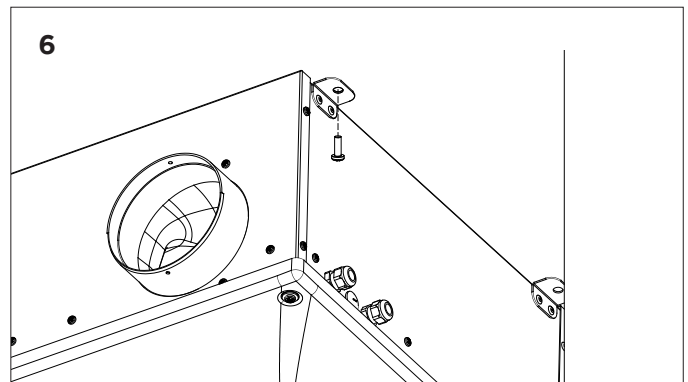

Use appropriate screws (not supplied) to fix the unit to the ceiling. It is recommended to fit the unit with anti-vibration mounts (not supplied).

FLOOR INSTALLATION

The unit must be installed in the following position.

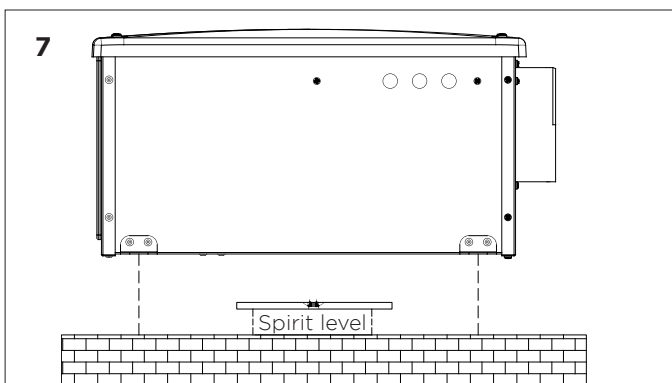

Prepare the surface where the unit is to be mounted. Make sure that the surface is flat, levelled and that it supports the weight of the unit. Perform the installation in accordance with local rules and regulations.

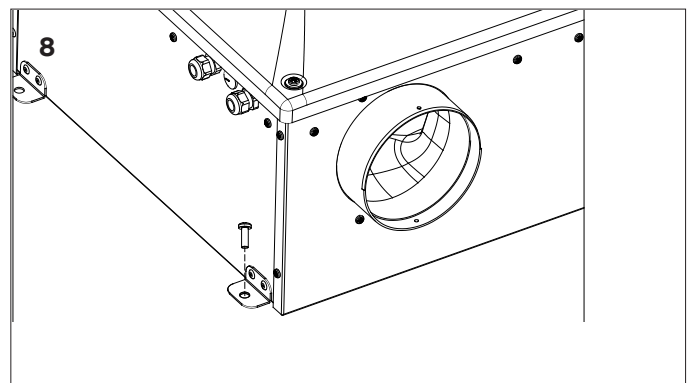

Use appropriate screws (not supplied) to fix the unit to the floor. It is recommended to fit the unit with anti-vibration mounts (not supplied).

01384 275771

info@eltatrade.co.uk

www.eltatrade.co.uk

ELECTRICAL CONNECTIONS, COMMISSIONING & OPERATION

WARNING: Make sure that the mains supply to the unit is disconnected before performing any installation, service, maintenance or electrical work. The installation and service of the unit and complete ventilation system must be performed by an authorised installer and in accordance with local rules and regulations.

WARNING: The unit must be earthed.

The unit has various modes of operation which can be chosen by a combination of dip switch selection, wiring, speed setting via the V1 trimmer knob and boost speed setting via the V2 trimmer knob.

Modes of operation:

- Default: pre-wired with 2 speed selection via remote switch (Fig. 9)
- Single speed operation (Fig. 11)
- Two speed operation with remote two-position switch/sensor (Fig. 12)

TABLE A: DIP SWITCH SELECTION

1	2	3	4	Operation selection via dip switch
0	0	0	1	Single speed
1	0	0	1	Two speed operation with external two position switch/sensor
0	1	0	1	Variable speed operation with CTRL-M remote manual controller
0	1	1	1	Variable speed operation through external 0-10v control
1	0	0	1	Three speed operation with SEL-3V speed selector

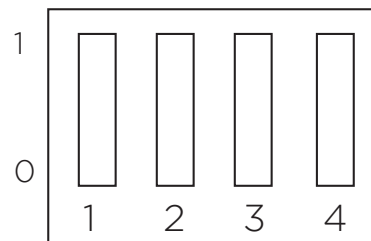
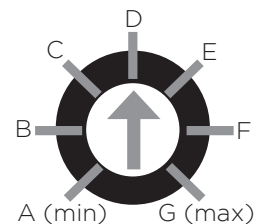

TABLE B: V1 AND V2 TRIMMER SPEED SETTING

Trimmer Position	m ³ /h	l/s	W
A (min)	61	17	3.7
B	76	21	4.3
C	104	29	7.5
D	144	40	12.0
E	180	50	17.3
F	198	55	21.0
G (max.)	216	60	24.2



01384 275771

info@eltatrade.co.uk

www.eltatrade.co.uk

PRE-CABLED ELECTRIC CONNECTIONS

The PIV ONE is wired internally from factory for two-speed operation with remote switch (not supplied). The speed is set by turning the integral trimmer “V1” on the internal electronic circuit (Fig. 10) and can be boosted to a second speed, which is set by turning the integral trimmer “V2”. The second speed is activated, when needed, by means of a remote switch.

Unit comes pre-wired with:

- mains supply cable (3-core: brown, blue, yellow/green).
- wiring cable to remote switch (2-core: blue, brown).

Factory setting:

- “V1” (first speed) 104m³/h (29l/s)
- “V2” (second speed) 216m³/h (60l/s)
- Dip switch configuration: 01001.

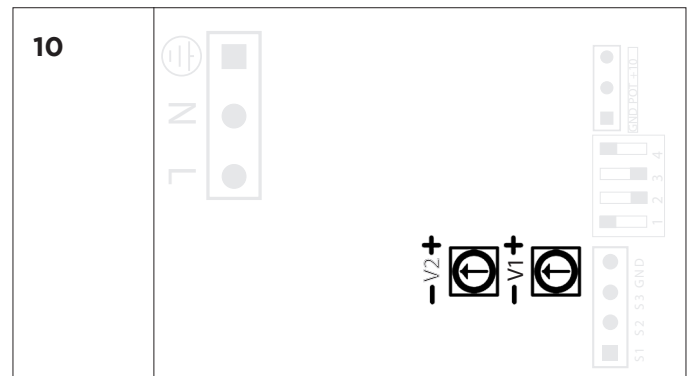
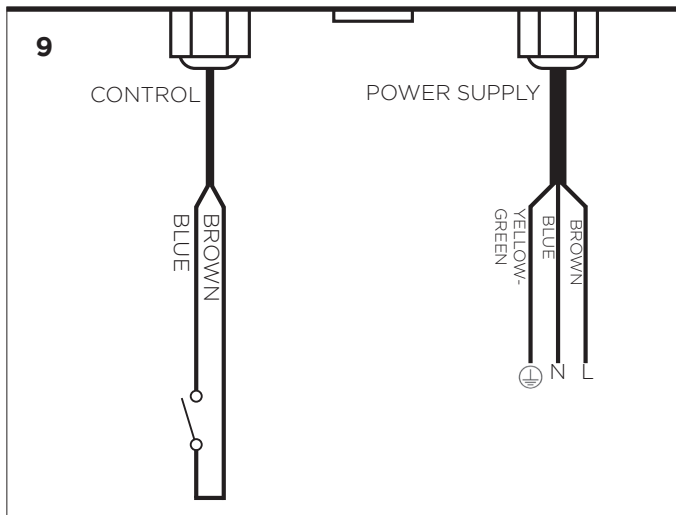

Speed adjustment trimmer on the internal electronic board.

ADDITIONAL ELECTRIC CONNECTIONS

WARNING: The installation and service of the unit and complete ventilation system must be performed by an authorised installer and in accordance with local rules and regulations.

WARNING: The unit must be earthed.

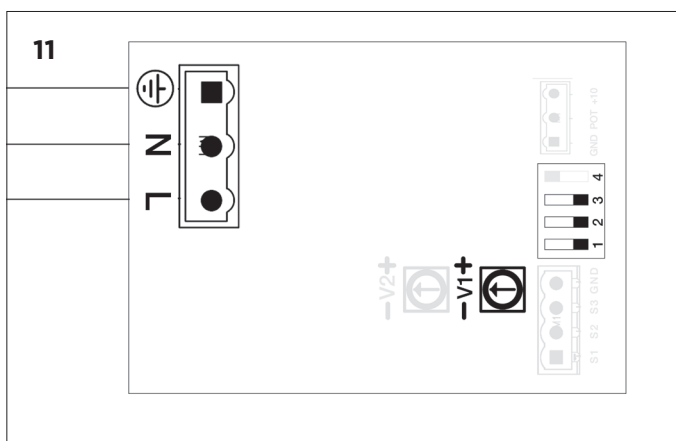

Single speed operation

- No need for control wiring
- Set dip switches as per diagram
- Adjust trimmer to desired speed as per Table B on page 6

NOTE: The PIV ONE can also be controlled by: Variable Pot, BMS systems, 0-10v Control. If this functionality is required, please contact us.

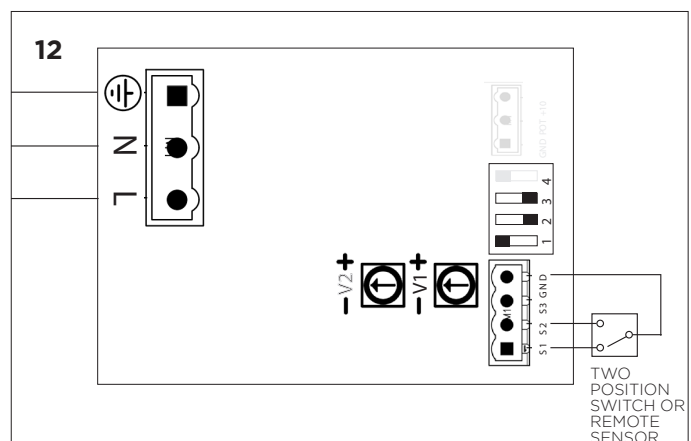

Two-speed operation with remote two-position switch/sensor

- Connect additional switch/sensor as per diagram
- Set dip switches as per diagram
- Adjust trimmer V1 to desired speed as Table B on page 6
- Adjust trimmer V2 to desired speed as Table B on page 6

MAINTENANCE

WARNING: Make sure that the mains supply to the unit is disconnected before performing any installation, service, maintenance or electrical work.

Follow the steps below for maintaining your PIV ONE.

1. Clean the pre-filter with a vacuum cleaner.
2. Clean the G4 filter with a vacuum cleaner.
3. Filters should be replaced every year, however the actual need to do so will vary depending on indoor and outdoor ambient conditions and how often it is cleaned.
4. Clean the diffuser as shown in the diagrams below.

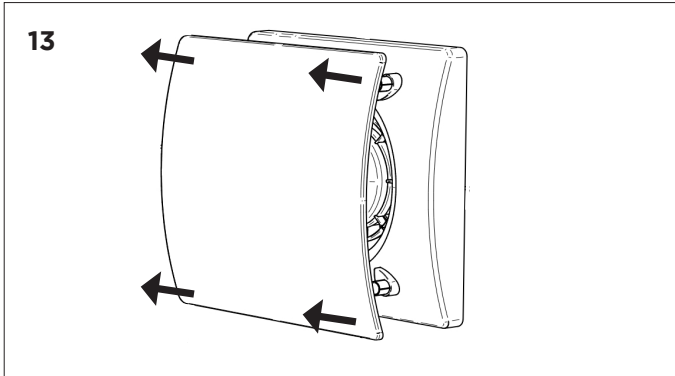

Remove the front cover.

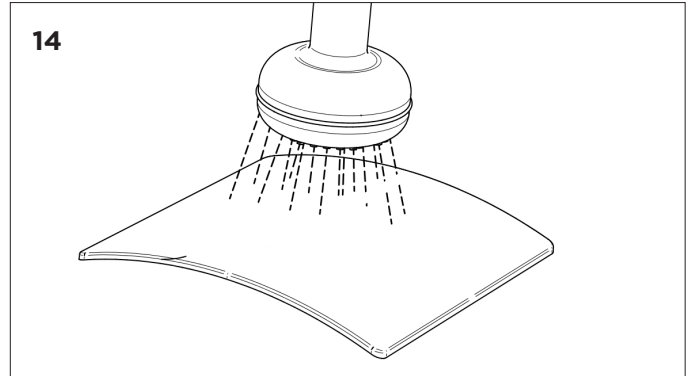

Wash the front cover.

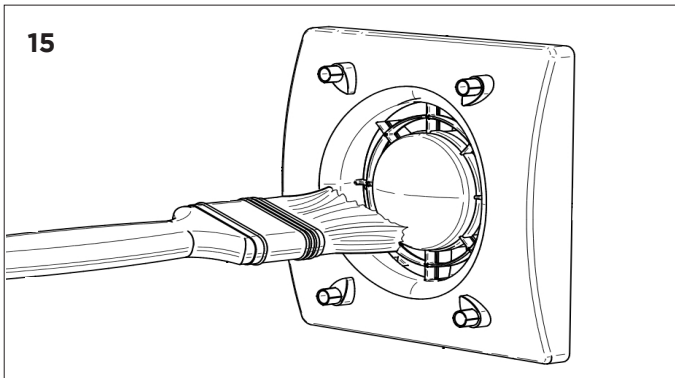

Remove any dirt from the unit with a soft bristled brush.

MAINTENANCE/CLEANING REGISTER

**FILTER
CLEANING**

**FILTER
REPLACEMENT**

DATE

DATE

DATE

DATE

DATE

ErP DIRECTIVE - REGULATIONS 1253/2014 - 1254/2014

a) Mark	-	ELTA TRADE	
b) Model	-	PIV ONE	
c) SEC class	-	C	E
c1) SEC warm climates	kWh	-10	-6.2
c2) SEC average climates	kWh	-24.4	-16.7
c3) SEC cold climates	kWh	-49.5	-35.1
Energy label	-	No	
d) Unit typology	-	Residential - unidirectional	
e) Type of drive	-	Multi speed drive	
f) Type of Heat Recovery System	-	Absent	
g) Thermal efficiency of heat recovery	%	N/A	
h) Maximum flow rate @100Pa	m ³ /h	216	
i) Electric power input at maximum flow rate	W	24	
j) Sound power level (L _{WA})	dBA	43	
k) Reference flow rate	m ³ /h	162	
l) Reference pressure difference	Pa	10	
m) Specific power input (SPI)	W/(m ³ /h)	0.089	
n1) Control factor	-	0.65	0.85
n2) Control typology	-	Local demand control Central demand control	
o1) Maximum internal leakage rate	%	N/A	
o2) Maximum external leakage rate	%	N/A	
p1) Internal mixing rate	%	N/A	
p2) External mixing rate	%	N/A	
q) Visual filter warning	-	N/A	
r) Instructions to install regulated grilles	-	Check the instruction booklet	
s) Internet address for pre/disassembly instructions	-	www.eltatrade.co.uk	
t) Airflow sensitivity to pressure variations	%	6	
u) Indoor/outdoor air tightness	m ³ /h	67	
v1) Annual electricity consumption - warm climates	kWh	0.7	1.0
v2) Annual electricity consumption - average climates	kWh	0.7	1.0
v3) Annual electricity consumption - cold climates	kWh	0.7	1.0
w1) Annual heating saved - warm climates	kWh	11.9	8.7
w2) Annual heating saved - average climates	kWh	26.2	19.2
w3) Annual heating saved - cold climates	kWh	51.3	37.6

01384 275771

info@eltatrade.co.uk

www.eltatrade.co.uk



WARRANTY

Our 5 year warranty is provided only to customers who purchased directly from us. If you purchased elsewhere then please contact them directly and they will let you know their warranty procedure. Our warranty covers repair or replacement of defective goods only. It does not cover any labour costs associated with defective product or component removal or installation, nor does it cover the cost of sending goods back to us for inspection. Our warranty is subject to storage, installation, commissioning, inspection and maintenance having been carried out in accordance with our Installation and Maintenance Instructions (supplied with each product) and which are also available to view, save or print from our website.

Scan the QR code or visit www.eltatrade.co.uk/warranty to view further warranty information.



DISPOSAL AND RECYCLING

Information on disposal of units at the end of life.

This product complies with EU Directive 2002/96/EC. The symbol of the crossed-out dustbin indicates that this product must be collected separately from other waste at the end of its life. The user must, therefore, dispose of the product in question at suitable electronic and electro-technical waste disposal collection centres, or else send the product back to the retailer when purchasing a new, equivalent type device.

Separate collection of decommissioned equipment for recycling, treatment and environmentally compatible disposal helps to prevent negative effects on the environment and on health and promotes the recycling of the materials that make up the equipment.

Improper disposal of the product by the user may result in administrative sanctions as provided by law.

ELTA >>>
TRADE

Elta Trade is brought to you by Elta Fans Ltd. 46 Third Avenue,
Kingswinford, West Midlands, DY6 7US. Manufactured in Italy.

01384 275771

info@eltatrade.co.uk

www.eltatrade.co.uk

A MEMBER OF  ELTA
GROUP



PIV ONE USER GUIDE

NOTE: The installer should go through the user guide with the home occupants and leave this with them for their reference.

WHAT IS A PIV ONE?

The PIV ONE is a loft mounted whole-house Positive Input Ventilation unit, designed to introduce fresh, clean, and filtered air into the central hallway or landing of your home.

HOW DOES IT WORK?

The fan is designed to work on a continuous basis supplying filtered air into your home. Please see "Fan operation" confirmed by Installer.

WHAT ARE THE BENEFITS?

The PIV ONE helps prevent condensation dampness related problems and to control other indoor air pollutants in your home.

HOW DO I OPERATE THE FAN?

Your PIV ONE will have been set up by the Installer to operate in one of a number of ways.

The Installer should indicate the method of "Fan operation" by ticking the appropriate box on the back of this sheet.

DOES IT NEED SERVICING?

The fan filter and diffuser need to be serviced regularly to maintain optimum performance in line with the instructions in the Installation & Maintenance manual which is available to download from our website.

HOW MUCH DOES IT COST TO RUN?

There are several variables that can determine the annual electrical running costs of the PIV ONE, however, at typical electricity costs as of June 2023, you should expect the fan to cost between £2-3 per year to run under normal conditions.

WHAT IF I THINK THERE IS A PROBLEM WITH THE FAN?

If you are a tenant, please report it to your landlord. If you are not, please contact the company you purchased the fan from.

IMPORTANT NOTE

PIV ONE fans are designed to run continuously. The power supply to the fan should only be disconnected if a fault is detected or suspected or when the fan is being maintained. Prolonged and/or repeated power interruption can create a health and safety risk and invalidate the fan warranty.



PIV ONE USER GUIDE

FAN OPERATION

Installer to tick as appropriate.

- The fan is fully automatic and will continuously supply filtered air into your home.
- The fan is fully automatic and will continuously supply filtered air into your home. In addition, it is linked to a sensor to provide a “boost” mode which will run the fan at a higher.
- The fan is fully automatic and will continuously supply filtered air into your home. In addition, it is linked to a switch to provide a choice of two preset speeds.
- Other (Installer to specify here)



Scan the QR code for product and warranty information.