

FSD-TD Series



Installation, Operation and Maintenance Instructions

THESE INSTALLATION INSTRUCTIONS MUST BE READ IN THEIR ENTIRETY BEFORE COMMENCING WORK TO ENSURE COMPLIANCE

Dampers will only be CE marked if:

- Installed as tested
- No deviation to design
- These instructions are followed

Third party approval will be required for any non-tested proposal.

Before commencing installation, the "Installation Check List" within DW/145 should be referred to. See "Damper Installation Certificate" on page 21.

Fitted actuators should not be demounted without first consulting with BSB Technical Support Team.

Important Information

1. Storage

- 1.1 Dampers received on site should be stored in a purpose made storage area, where they can be protected from moisture, dust, and impact damage until required. Dampers are designed for installation within internal normal dry filtered H&V systems.

2. Health and Safety

- 2.1 Only competent personnel may carry out the work outlined within this document.
- 2.2 The wearing of appropriate Personal Protective Equipment (gloves, footwear, safety glasses etc.) is required for safe working and as the site dictates.
- 2.3 Dampers may be heavy. Large dampers will require suitable lifting and supporting equipment, with due consideration given for manual handling.
- 2.4 Dampers may close without warning. Do not introduce limbs/fingers between blades whilst the actuator is fitted, and blades are open.
- 2.5 Where dampers are only accessible with the need for additional elevation, any equipment used should be done so with due consideration to the Work at Height regulations 2005 and current site rules.
- 2.6 All work should be carried out in accordance with HSE guidelines and regulations and any specific local site rules.

3. Important

- 3.1 These instructions should be read in its entirety before commencing work. The installer must be Competent with the manufacturer's fire barrier separating element construction.
- 3.2 Do not lift damper by the blades as this will compromise the damper performance.
- 3.3 Actuators are IP54 rated – Check actuator connection box is suitably located.
- 3.4 Do not cut/shorten the Thermal Fuse lead (TF) on TF Actuators. This will render the unit inoperable and invalidate the warranty.
- 3.5 TF must be fitted in accordance with section "24. Thermal Fuse (TF)" on page 18. Failure to meet this requirement will invalidate the warranty and the damper will fail to respond as designed/tested.
- 3.6 All Fire / Smoke Damper installations must be installed to a BSB tested method and carried out to the satisfaction of the appropriate Building Control officer and/or specifying authority.
- 3.7 Refer to actuator label for "Wiring Instruction" on page 18.
- 3.8 Refer to section "26. Routine Inspection, Testing and Maintenance" on page 19 for testing. Complete "Damper Installation Certificate" on page 23 and retain for future reference.
- 3.9 For existing dry walls – When cutting the opening for damper, and (partial) removal of stud is unavoidable, ensure the structure is sufficiently supported to conform to the design specification.
- 3.10 Dry wall openings must be lined. See Fig. 3 on page 6.
- 3.11 Ensure that appropriate 'fire-rated' plasterboard is used throughout the construction of drywall partitions that need to act as fire separation barriers.
- 3.12 Ductwork to be fitted and connected to the damper spigot in accordance with DW 144/145. Aluminium rivets should be used (to act as breakaway joint).
- 3.13 Where more than one duct penetrates a wall or floor, adjacent fire damper assemblies should be separated by a structural element with a minimum width of 200mm (to comply with BS EN1366-2 13.6).
- 3.14 Minimum distance from adjacent dampers and structures must be applied. Fire dampers must be separated by a structural 200mm minimum distance between cases and have a minimum 75mm between the fire damper case and a construction element (wall, floor and/or ceiling). Other services should not share the same opening as the installed damper.

4. Equipment Required

- 4.1 Equipment and tools will vary dependent upon the fire barrier construction that the damper is being installed within. Standard equipment normally used for the building of the particular barrier should suffice.
- 4.2 Access equipment, as necessary.
- 4.3 Temporary support equipment (to retain damper in position).
- 4.4 Cordless drill with 2,5mm and 10mm drill bits for fitting TF.
- 4.5 4mm (drywall) and 8mm (concrete/masonry) drill bits as required, for the AF fixing frame fixing holes.
- 4.6 Phillips screwdriver to suit thermal fuse screws.
- 4.7 Screwdriver to suit junction box terminals (by others).
- 4.8 8mm A/F spanner for motor fixing bolt.
- 4.9 12mm A/F Spanner for TD drive shaft.
- 4.10 Tape measure calibrated to check adequate space is available to install the damper and to establish correct finished aperture has been achieved.

5. Preparation for Installation

- 5.1 For each damper installation type, refer to the relevant installation detail.
- 5.2 Remove packaging materials with the exception of the actuator packaging - leaving this in place will protect the actuator wiring / thermal fuse whilst the damper is being installed.
- 5.3 Before installation, the damper should be inspected to ensure that it has not been damaged and is in good condition.
- 5.4 Check damper (label) reference and size to site specification.
- 5.5 Check actuator voltage is correct.
- 5.6 Determine required position of damper. Check sufficient space exists to fit the product. Ensure any services (e.g. electrical/plumbing) within the structure do not impact on the damper when installed.
- 5.7 Drill the relevant peripheral EASY FIX® pilot holes for the wall type.

6. Damper Aperture Preparation

Separation between multiple fire dampers and/or fire dampers and construction elements

- 6.1 In accordance with EN 1366-2: 2015 and the direct application rules, where two fire dampers are installed adjacent to each other within a fire separating element, each damper must be installed within its own prepared aperture and there must be 200mm clear structural separation between the damper casings
- 6.2 There must also be a minimum of 75mm between the damper casing and the construction element wall, floor or ceiling on all four sides.
- 6.3 The Dry Wall tested method specification refers to a symmetrical designed wall with two D&F fire boards 12.5mm thick per side onto a 50mm deep steel frame. The void was filled with stone wall insulation that can be optional in the construction of the dry line wall.

7. Thermal Fuse Installation

- 7.1 Where connecting ductwork is installed fit the thermal fuse into position using the template provided referring to section 24 on page 18 for positioning.
- 7.2 Where ductwork has not been connected, ensure that the thermal fuse is not left hanging by the connecting lead. It should be stored in a way that allows the thermal fuse probe to be protected prior to being fitted. It is recommended that the actuator packaging that also houses the thermal fuse during transportation, is left in situ until the connecting ductwork has been installed.

Fig. 1: Thermal Fuse (TF)

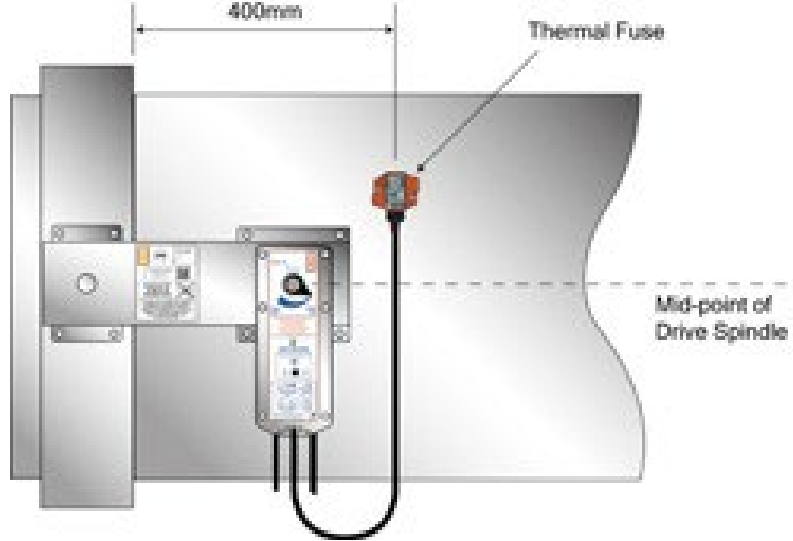

Dry Wall Tested Installation Methods

8. None Cleated Frameless Installation (Refer to FSD-TD M5)

8.1 Important Information

- 8.1.1 Preferably, prepare the opening whilst building the fire separation barrier, or cut opening if barrier exists. (See section 7.2)
- 8.1.2 The finished aperture size should have an allowance of 10mm between the damper case and the finished aperture size top and bottom and an allowance of 10mm on the non-actuator side and 35mm on the actuator side between the damper case and finished aperture size. Nominal duct width +121mm and nominal duct height +96mm.

8.2 Preparing the Aperture

- 8.2.1 Mark out the position and size required on the wall, taking into account the fire board thickness used for lining out and the installation allowance per side. Please also ensure that the position of the damper when installed allows for the minimum 75mm between the damper casing and the construction element wall or floor on all four sides. Each damper must be installed within its own prepared aperture without sharing this space with other services.
- 8.2.2 Using appropriate means (e.g. jig saw), cut the hole in the wall, removing each layer and any infill that is present.
- 8.2.3 Cut 2 pieces of steel track equal to the opening width.
- 8.2.4 Fit track to top and bottom of opening between and level with the fire board, screwing in position to the track from both sides of wall at each end with drywall screws and at maximum 300mm centres.
- 8.2.5 Cut 2 more pieces of track equal to the opening height and secure into place with drywall screws as above.
- 8.2.6 Cut 4 'batons' of fire board to suit opening. Screw each baton with 25mm drywall screws at max. 300mm pitch to the track that is lining the opening without damaging the fire board.
- 8.2.7 Ensure batons are flush with the surfaces of the wall and do not protrude.
- 8.2.8 Depending on wall thickness, it may ease connection of ductwork, if connecting ductwork is attached to damper prior to fitting pattress to the wall around the damper.
- 8.2.9 Prepare a pair of spacing blocks, (approx. 10mm high x 25mm square) from any available material (such as drywall boards). Position spacing blocks within the opening at extremities of damper and stand the damper on blocks so that damper is central in opening, with blades running horizontally.

- 8.2.10 Prepare 16 off pattress pieces from plasterboard of same material as main construction. Plasterboard pattress should be typically 120mm – 150mm wide but sufficiently in size to butt up to damper spigots/duct and overlap the outer edge of the track lining the opening by at least 10mm. The length needs to be long enough to form neat comers.
- 8.2.11 Two layers of pattress are required each side of the wall and the corners should 'overlap' between the first and second layers.
- 8.2.12 Fit the pattress using dry wall screws.
- 8.2.13 Fit second pattress detail to other side of wall in similar manner.
- 8.2.14 It is not a necessity to fill the void between the pattles, but it can be done for insulation purposes if desired with non-intumescent material.
- 8.2.15 **IMPORTANT:** Ensure the drywall screws 'pick up' the track lining the aperture, so that the proper fire integrity of the installation will not be compromised.

8.3 Thermal Fuse Installation

- 8.3.1 See section "23. Thermal Fuse (TF)" on page 18.

9. Pattress and Cleat Installation (Refer to FSD -TD M6)

9.1 Important Information

- 9.1.1 The finished aperture size should have an allowance of 10mm between the damper case and the finished aperture size top and bottom and an allowance of 40mm on the non-actuator side and 40mm on the actuator side between the damper case and finished aperture size.
- 9.1.2 Nominal duct width +156mm to all for cleats where fitted and nominal duct height +96mm.

9.2 Preparing the Aperture

- 9.2.1 Mark out the position and size required on the wall, taking into account the fire board thickness used for lining out and installation allowance. Please also ensure that the position of the damper when installed allows for the minimum 75mm between the damper casing and the construction element wall or floor on all four sides. Each damper must be installed within its own prepared aperture without sharing this space with other services.
- 9.2.2 Using appropriate means (e.g. jig saw), cut the hole in the wall, removing each layer and any infill that is present.
- 9.2.3 Cut 2 pieces of steel track equal to the opening width.
- 9.2.4 Fit track to top and bottom of opening between and level with the fire board, screwing in position to the track from both sides of wall at each end with drywall screws and at maximum 300mm centres.
- 9.2.5 Cut 2 more pieces of track equal to the opening height and secure into place with drywall screws as above.
- 9.2.6 Cut 4 'batons' of fire board to suit opening. Screw each baton with 25mm drywall screws at maximum 300mm pitch to the track that is lining the opening without damaging the fire board.
- 9.2.7 Ensure batons are flush with the surfaces of the wall and do not protrude.
- 9.2.8 The finished prepared aperture should look like Fig. 3 on page 7.
- 9.2.9 Depending on wall thickness, it may ease connection of ductwork, if connecting ductwork is attached to damper prior to fitting pattress to the wall around the damper.
- 9.2.10 Prepare a pair of spacing blocks, (approx. 10mm high x 25mm square) from any available material (such as drywall boards). Position spacing blocks within the opening at extremities of damper and stand the damper on blocks so that damper is central in opening, with blades running horizontally.
- 9.2.11 Prepare 16 off pattress pieces from plasterboard of same material as main construction. Plasterboard pattress should be typically 120mm – 150mm wide but sufficiently in size to butt up to damper spigots/duct and overlap the outer edge of the track lining the opening by at least 10mm. The length needs to be long enough to form neat corners.
- 9.2.12 Two layers of pattress are required each side of the wall and the corners should 'overlap' between the first and second layers. Fit the pattress using dry wall screws.
- 9.2.13 Fit second pattress detail to other side of wall in similar manner.
- 9.2.14 It is not a necessity to fill the void between the pattresses, but it can be done for insulation purposes if desired with non-intumescent material.
- 9.2.15 **IMPORTANT:** Ensure the drywall screws 'pick up' the track lining the aperture, so that the proper fire integrity of the installation will not be compromised.

9.3 Thermal Fuse Installation

- 9.3.1 See section "23. Thermal Fuse (TF)" on page 18.

10. AF Fixing Frame Installation (Refer to FSD-TD M9)

10.1 Important Information

- 10.1.1 The finished aperture size should have an allowance of 10mm between the damper case and the finished aperture size top and bottom and an allowance of 10mm on the non-actuator side and 35mm on the actuator side between the damper case and finished aperture size. The thickness of the fire board used for lining out the aperture must also be taken into account.
- 10.1.2 Nominal duct width +122mm and nominal duct height +99mm. See Fig. 3.

10.2 Preparing the Aperture

- 10.2.1 Make sure that the intended position of the damper can be achieved observing the minimum separation dimension between fire dampers and construction elements. Refer to 8.2 on page 4. Other services should not share the same opening as the installed damper. Mark out the position and size of the required cut size on the wall. Using appropriate means (e.g. jig saw, cut the hole in the wall, removing each layer and any infill that is present.

Fig. 2: FSD-TD Drywall Spacing

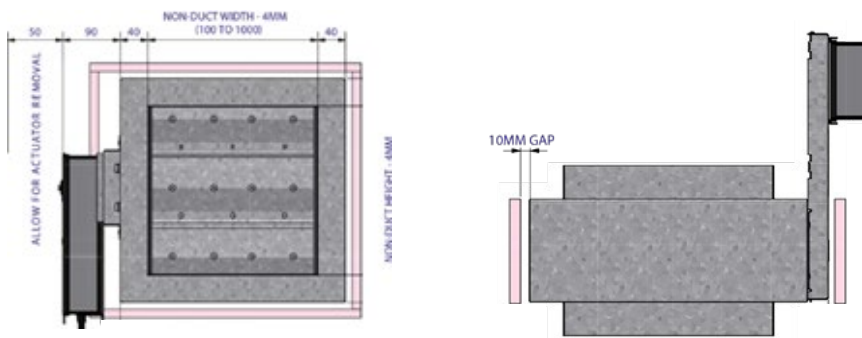
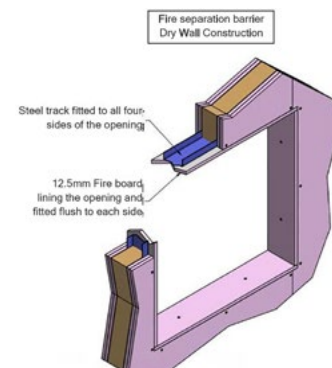

Fig. 3: Drywall Construction



- 10.2.2 Cut 2 pieces of steel track equal to the opening width.
- 10.2.3 Fit track to top and bottom of opening between and level with the fire board, screwing in position to the track from both sides of wall at each end with drywall screws and at maximum 300mm centres.
- 10.2.4 Cut 2 more pieces of track equal to the opening height and secure into place with drywall screws as above.
- 10.2.5 Cut 4 'batons' of fire board to suit opening. Screw each baton with 25mm drywall screws at maximum 300mm pitch to the track that is lining the opening without damaging the fire board. Ensure batons are flush with the surfaces of the wall and do not protrude.
- 10.2.6 Prepare a pair of spacing blocks, (approx. 10mm high x 25mm square) from any available material (such as drywall boards). This will aid spacing the damper centrally in the height when installing.

10.3 Preparing the Damper

- 10.3.1 Drill out the inner row of 2mm diameter angle frame pilot holes to 4mm diameter on all four sides.
- 10.3.2 Position the previously prepared spacing blocks within the opening at the extremities of damper and stand the damper on the spacing blocks so that damper is central in the opening, with the blades running horizontally.
- 10.3.3 Using the inner row of pilot holes, screw the EASY FIX® angle frame to the wall using drywall screws at 150mm max. pitch picking up track lining the hole.
- 10.3.4 There is no requirement to fit a pattress on the reverse side of the damper or fill the void between the damper case and prepared aperture.

10.4 Thermal Fuse Installation

- 10.4.1 Where connecting ductwork is installed fit the thermal fuse into position using the template provided referring to section 23 on page 20 for positioning.
- 10.4.2 Where ductwork has not been connected, ensure that the thermal fuse is not left hanging by the connecting lead. It should be stored in a way that allows the thermal fuse probe to be protected prior to being fitted. It is recommended that the actuator packaging that also houses the thermal fuse during transportation, is left in situ until the connecting ductwork has been installed.

Masonry Wall Installation Methods

11. Masonry Wall - (AF) Easy Fix® Angle Frame Installation (Refer to FSD-TD M10)

11.1 Important Information

- 11.1.1 Preferably, prepare the opening whilst building the wall, or cut an opening if the wall already exists. The damper is not load-bearing and additional support to the top of the wall opening is required by means of a lintel or other approved method.
- 11.1.2 Make sure that the intended position of the damper can be achieved observing the minimum separation dimension between fire dampers and between fire dampers and construction elements. Refer to section 5 on page 3. Other services should not share the same opening as the installed damper.
- 11.1.3 The finished aperture size should have an allowance of 10mm between the damper case and the finished aperture size top and bottom and an allowance of 10mm on the non-actuator side and 35mm on the actuator side between the damper case and finished aperture size.
- 11.1.4 Nominal duct width +122mm and nominal duct height +99mm.
- 11.1.5 Mark out the position and size of the required cut size on the wall. Using appropriate means (e.g. skill saw or other masonry cutter), cut the hole in the wall. Do not remove whole blocks or bricks around the perimeter as an oversized aperture will not be compliant and will require third party approval.
- 11.1.6 Prepare a pair of spacing blocks, (approx. 10mm high x 25mm square) from any available material (such as drywall boards). This will aid spacing the damper centrally in the height when installing.

11.2 Preparing the Damper

- 11.2.1 Drill out the outer row of 2mm diameter angle frame pilot holes to the appropriate size for the fixings being used. Position the previously prepared spacing blocks within the opening at the extremities of damper and stand the damper on the spacing blocks so that damper is central in the opening, with blades running horizontally.
- 11.2.2 Using the enlarged fixing holes as a template, mark the fixing holes on the wall and remove the damper.
- 11.2.3 Drill the appropriately sized fixing hole into the concrete wall to suit the fixings to be used.
- 11.2.4 Replace the damper into the aperture and ensure that it sits equally in the width and height and the AF fixing frame sits flat to the wall. Using the outer prepared row of holes, screw the EASY FIX® angle frame to the wall using suitable steel sleeved fixings at 150mm max. pitch.
- 11.2.5 **IMPORTANT:** Ensure that the fixing used are located 20mm minimum from the aperture edges, so that the proper fire integrity of the installation will not be compromised.

11.3 Thermal Fuse Installation

- 11.3.1 Where connecting ductwork is installed, fit the thermal fuse into position using the template provided referring to section 23 on page 20 for positioning.
- 11.3.2 Where ductwork has not been connected, ensure that the thermal fuse is not left hanging by the connecting lead. It should be stored in a way that allows the thermal fuse probe to be protected prior to being fitted. It is recommended that the actuator packaging that also houses the thermal fuse during transportation, is left in situ until the connecting ductwork has been installed.

Masonry Floor Installation Methods

12. Masonry Floor– (AF) EASY FIX® Angle Frame Installation (Refer to FSD-TD M11)

12.1 Important Information

- 12.1.1 Preferably, the opening would have already been formed to the correct size. Where the prepared aperture is oversized, please refer back to the principal designer.
- 12.1.2 Where the aperture has not been formed, mark out the position and size on the floor. Make sure that the intended position of the damper can be achieved observing the minimum separation dimension between the fire damper and construction elements. Refer to section 5 on page 3. Other services should not share the same opening as the installed damper.
- 12.1.3 The finished aperture size should have an allowance of 10mm between the damper case and the finished aperture size top and bottom and an allowance of 10mm on the non-actuator side and 35mm on the actuator side between the damper case and finished aperture size.
- 12.1.4 Nominal duct width +122mm and nominal duct height +99mm.
- 12.1.5 Cut an opening in the floor ensuring that the correct finished size is achieved. A skill saw or other masonry cutter will suffice.
- 12.1.6 When placing the damper into the hole, ensure that it sits central in both width and depth.
- 12.1.7 With damper in place, drill the 2mm diameter outer pilot holes out and into the concrete floor to a shallow depth just to mark the positioning of the holes in the floor to the appropriate size.
- 12.1.8 Remove the damper from the aperture and drill further the securing holes into the concrete using the identification marks made using a 6.5mm diameter drill.
- 12.1.9 It is not a necessity to fill the void behind the angle frame.
- 12.1.10 **Important:** Ensure that the fixing anchors are located 20mm minimum from the opening's edges, so that the proper fire integrity of the installation will not be compromised.

12.2 Thermal Fuse Installation

- 12.2.1 Where connecting ductwork is installed fit the thermal fuse into position using the template provided referring to section 23 on page 20 for positioning.
- 12.2.2 Where ductwork has not been connected, ensure that the thermal fuse is not left hanging by the connecting lead. It should be stored in a way that allows the thermal fuse probe to be protected prior to being fitted. It is recommended that the actuator packaging that also houses the thermal fuse during transportation, is left in situ until the connecting ductwork has been installed.

(HV) HEVAC Wall Frame Installation

13. (HV) HEVAC Wall Frame Installation (Refer to FSD-TD M2)

13.1 Important Information

- 13.1.1 Preferably, the opening would have already been formed to the correct size. Where the prepared aperture is oversized, please refer back to the principal designer.
- 13.1.2 Finished sizes should be 50mm minimum to 75mm max. greater than the HEVAC frame assembly extremities. This applies to both block work and concrete wall applications.
- 13.1.3 The damper is not load-bearing and additional support for the top of the wall opening is achieved by means of a lintel or other approved method.
- 13.1.4 Fit looped steel wall anchors (Ø6mm min.) all round the inside of the opening in corresponding positions to the HEVAC frame builder's ties. For low density blocks use Loden Anchor fixings.
- 13.1.5 Bend the builder's ties out. See Fig. 4.
- 13.1.6 Prepare a pair of spacing blocks, (approx. 10mm high x 25mm square) from any available material (such as drywall boards). This will aid spacing the damper centrally in the height when installing.
- 13.1.7 While supporting the damper centrally in the prepared aperture, secure the builders ties to the looped wall anchors with 1.5mm galvanized steel wire (The loops must be tight and a minimum of 3 loops is recommended). See Fig. 5.
- 13.1.8 Fill the surrounding void with 4:1 mortar and finish to desired standard.

Fig. 4: Bent out builders ties

Fig. 5: Steel wire wrapped around building in tie and steel fixing

Fig. 6: Loden Anchors

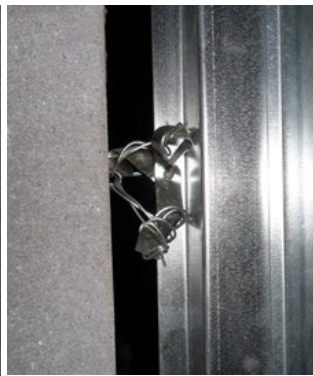

13.2 Fixings and Equipment

- 13.2.1 Loden anchors are only suitable for low density walls.
- 13.2.2 HA50 – 5mm diameter 50mm long flat head (for angle frame/installation plate).
- 13.2.3 LB60 6.5mm diameter 60mm long looped end (for wiring in HEVAC frame).
- 13.2.4 Standard steel expanding anchors for high density bricks and concrete.

13.3 Thermal Fuse Installation

- 13.3.1 Where connecting ductwork is installed fit the thermal fuse into position using the template provided referring to section 23 on page 20 for positioning.
- 13.3.2 Where ductwork has not been connected, ensure that the thermal fuse is not left hanging by the connecting lead. It should be stored in a way that allows the thermal fuse probe to be protected prior to being fitted. It is recommended that the actuator packaging that also houses the thermal fuse during transportation, is left in situ until the connecting ductwork has been installed.

(HF) HEVAC Floor Frame Installation

14. (HF) HEVAC Floor Installation Methods (Refer to FSD-TD M1)

14.1 Important Information

- 14.1.1 The finished aperture size should have an allowance of 10mm between the damper case and the finished aperture size top and bottom and an allowance of 10mm on the non-actuator side and 35mm on the actuator side between the damper case and finished aperture size.
- 14.1.2 Nominal duct width +122mm and nominal duct height +99mm.
- 14.1.3 Where the aperture in the floor has not been formed, mark out the position and size on the floor.
- 14.1.4 Make sure that the intended position of the damper can be achieved observing the minimum separation dimension between the fire damper and construction elements. Refer to section 5 on page 3. Other services should not share the same opening as the installed damper.
- 14.1.5 Cut an opening in the floor ensuring that the correct finished size is achieved. A skill saw or other masonry cutter will suffice.
- 14.1.6 When the aperture has been correctly formed. Fit looped steel wall anchors (6mm Ø min.) all round the inside of the opening in corresponding positions to the HEVAC frame builder's ties. For low density blocks use Loden Anchor fixings.
- 14.1.7 Bend the builder's ties out on the HEVAC damper frame. See Fig. 4.
- 14.1.8 Place the damper within the prepared aperture and while supporting the damper centrally in the prepared aperture, secure the builders ties to the looped wall anchors with 1.5mm galvanized steel wire. The loops must be tight and a minimum of 3 loops is recommended. See Fig. 6.
- 14.1.9 Fill the surrounding void above and below with 4:1 mortar and finish to desired standard.
- 14.1.10 When placing the damper into the hole, ensure that it sits central in both width and depth.
- 14.1.11 **Important:** Ensure that the fixing anchors are located 20mm min. from the opening's edges, so that the proper fire integrity of the installation will not be compromised.

14.2 Thermal Fuse Installation

- 14.2.1 Where connecting ductwork is installed fit the thermal fuse into position using the template provided referring to section 23 on page 20 for positioning.
- 14.2.2 Where ductwork has not been connected, ensure that the thermal fuse is not left hanging by the connecting lead. It should be stored in a way that allows the thermal fuse probe to be protected prior to being fitted. It is recommended that the actuator packaging that also houses the thermal fuse during transportation, is left in situ until the connecting ductwork has been installed.

Rockwool Ablative Batt Penetration Seal

15. Rockwool Ablative Batt Penetration Seal (Refer to FSD-TD M12)

15.1 Important Information

- 15.1.1 Prepare the Dry Line Wall section, two layers of fire board either side of the metal track forming the aperture and line with a single layer of fire board.
- 15.1.2 Using threaded drop rods of the correct length affixed to the underside of the slab/soffit, pass the other end through the damper cleat hole to provide support prior to fitting the fire batt into position. Use 2 locking nuts on each drop rod to the underside of the fitted cleat. Do not use nuts above the cleat as this will restrict expansion in a fire condition. Repeat this for the other fitted cleat. See Fig. 7. for general connection detail. Two persons recommended for this installation.
- 15.1.3 Ensure the damper is level and will align with any connecting ductwork when fitted later.
- 15.1.4 All the fire batt connecting edges including the perimeter of the fire batt and between the AF fixing frame return have fire batt Fire Pro glue applied as directed by the manufacturers. The Fire Batt is better to be slightly over sized that allows for a firm push into place, than fitted loosely.
- 15.1.5 Once the Fire Batt has been fitted, apply a 10-15mm bead of Rockwool FirePro acoustic intumescent sealant around the perimeter of the fire batt on both sides.
- 15.1.6 It is preferable to allow the intumescent sealant to fully cure before connecting any ductwork. Check with the manufacturer for setting time.
- 15.1.7 Ensure that the Thermal Fuse that is wired into the fitted actuator remains protected until fitted into the connecting ductwork.

15.2 Thermal Fuse Installation

- 15.2.1 Where connecting ductwork is installed fit the thermal fuse into position using the template provided referring to section 23 on page 20 for positioning.
- 15.2.2 Where ductwork has not been connected, ensure that the thermal fuse is not left hanging by the connecting lead. It should be stored in a way that allows the thermal fuse probe to be protected prior to being fitted. It is recommended that the actuator packaging that also houses the thermal fuse during transportation, is left in situ until the connecting ductwork has been installed.

Fig. 7: Drop-rod load bearing specification

Drop-rod Size	Max. load per pair of studs (kg)		
	E60	E120	E240
M6	54.7	36.5	21.9
M8	100.4	66.9	40.2
M10	159.8	106.6	63.9
M12	233.1	155.4	93.2

Fig. 8: Drop-rod locking nut application

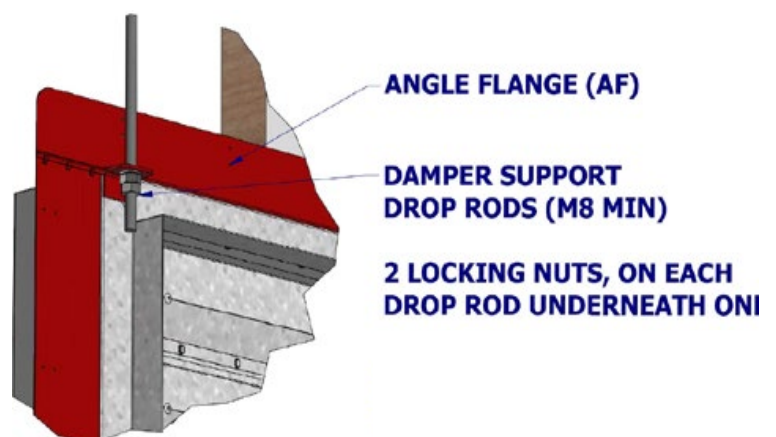

Permitted Multiple Arrangements

Multiple arrangement damper installations where tested are installed based on the same principals as for a single section damper and are CE compliant when supplied as the following detail.

Dampers can only be offered with an AF fixing frame available as factory fitted or loose for site assembly by others.

16. Vertical installations

Permitted multiple arrangements up to two units high and any quantity of units wide, providing that they are structurally supported to a fire safe design provided by a structural engineer.

17. Horizontal installations

- 17.1 Permitted multiple arrangements up to two units in one direction and any quantity of units in the other direction. The tested installation and support method must be followed. Deviation from the tested support detail will require a fire safe design approved by a structural engineer.
- 17.2 For larger installations we always suggest that building control are advised to ensure that there are no reasons to reject the proposed installation.
- 17.3 Joining channels will be provided for both sides of the assembly and will have capped ends to provide the benefit of a continuous perimeter spigot.
- 17.4 When there are transportation restrictions, large multiple units will be shipped in individual sections for site assembly by others. Joining channels are supplied un-drilled unless requested. Large multiple units required to be shipped fully assembled will incur additional packing/shipping costs. Please contact our sales office for further information.

18. Joining channels

Joining channels are provided numbered and should be used in the position shown below. There is no sequence for applying the joining channel.

Fig. 9: Joining Channels

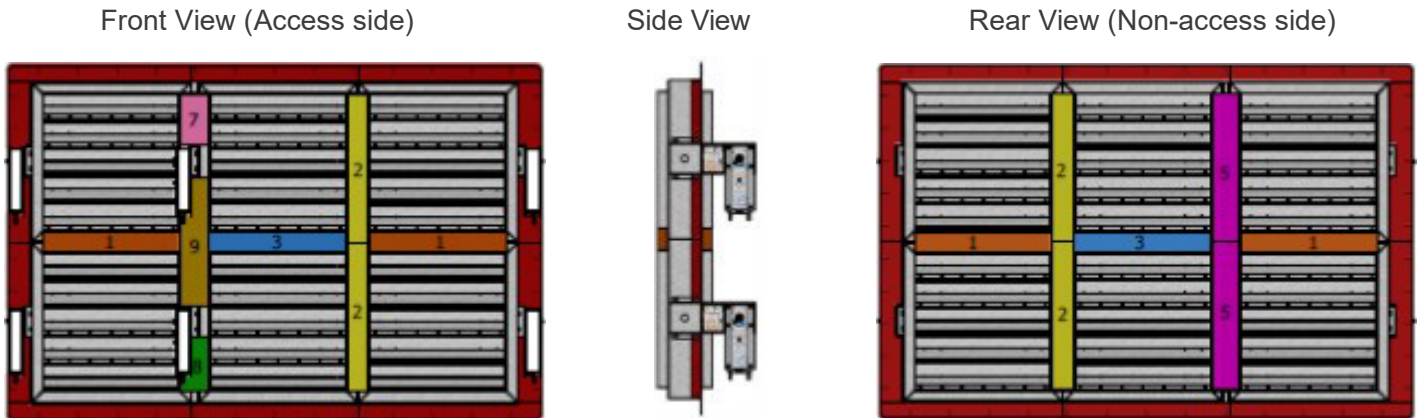

Dry Wall Tested Installation Method

19. AF Fixing Frame Installation (Refer to M9 MULTI)

19.1 Important Information

- 19.1.1 The assembly of multiple dampers will require a minimum of two persons.
- 19.1.2 The preparation of apertures for Dampers with multiple sections follow the same principals as a single section installation.
- 19.1.3 The finished aperture size should have an allowance of 10mm between the damper perimeter case and the finished aperture size top and bottom and an allowance of 35mm on the left and right hand sides between the damper case and finished aperture size. The thickness of the fire board used for lining out the aperture must also be taken into account. The tested method used one piece of 12.5mm thick fire board per side to line the aperture.
- 19.1.4 Nominal duct width +145mm and nominal duct height +99mm.

19.2 Preparing the Aperture

- 19.2.1 Make sure that the intended position of the damper can be achieved observing the minimum separation dimension between the assembled fire damper and construction elements. Refer to 8.2 on page 4. Other services should not share the same opening as the installed damper assembly. Mark out the position and size of the required cut size on the wall. Using appropriate means (e.g. jig saw, cut the hole in the wall, removing each layer and any infill that is present.
- 19.2.2 Ensure that the wall construction is adequate to support the assembled damper weight. Additional support may be required to ensure a fire safe design.
- 19.2.3 Cut 2 pieces of steel track equal to the opening width (this can be in sections to suit the length).
- 19.2.4 Fit track to top and bottom of opening between and level with the fire board, screwing in position to the track from both sides of wall at each end with drywall screws and at maximum 300mm centres.
- 19.2.5 Cut 2 more pieces of track equal to the opening height and secure into place with drywall screws as above.
- 19.2.6 Cut 4 'batons' of fire board to suit opening. Screw each baton with 25mm drywall screws at maximum 300mm pitch to the track that is lining the opening without damaging the fire board. Ensure batons are flush with the surfaces of the wall and do not protrude.
- 19.2.7 Prepare spacing blocks, (approx. 10mm high x 25mm square) from any available material (such as drywall boards). This will aid spacing the damper centrally in the height when installing.

19.3 Preparing the Damper

- 19.3.1 Components required:
 - Damper sections – Check quantity required.
 - Joining sections – packed separately.
 - Fire rated mastic (not intumescent).
 - Steel rivets Ø5mm x 8mm/10mm
- 19.3.2 Tools required:
 - Mechanical lifting equipment.
 - Temporary support equipment to retain damper in position prior to being fully fixed.
 - Cordless drill with 2.5mm and 10mm drill bits for fitting TF.
 - 4mm drill bits (drywall) to drill the fixing holes in the frame.
 - Phillips No2 screwdriver to suit thermal fuse screws.

- 19.3.3 Ensure that you have adequate space to assemble the damper, as you will need to work around the perimeter of the damper during assembly. You will need to assemble the damper in the horizontal position on a flat level surface to ensure that the damper is assembled square and to the correct size. Installing directly to the wall in sections one damper at a time is acceptable but may require additional persons.
- 19.3.4 Place the dampers side by side with the TD arm facing upwards. You will now be looking at the rear of the damper. Push the dampers together so that the pattern looks the same as Fig. 9.
- 19.3.5 Measure the overall assembled damper spigot size and make sure that it replicates the damper size ordered. It may be a few millimetres out until the dampers are mechanically fixed together.
- 19.3.6 Before attaching the provided joining sections, check that you have the correct quantity to suit both sides and familiarise yourself where each one fits. They are not all the same length or width. Please see Fig. 9.
- 19.3.7 Make sure that the correct joining channels are laid loose between the damper section spigots to ensure that you have the correct corresponding sections.
- 19.3.8 The capped end of the joining sections go to the outside of the assembly and the open end section should point inwards.
- 19.3.9 Once you are sure that the damper sections are correctly positioned and you have the correct joining sections, you can then join the damper sections together applying a single line of mastic to one damper side full height, placing the next damper section to that damper making sure that they align and fit the joining section using steel rivets.
- 19.3.10 Follow this process until all the dampers have been joined together.
- 19.3.11 Check the assembled spigot size, is this the correct size?
- 19.3.12 Once this has been established you will need to fit the joining sections to the other side.
- 19.3.13 With care and assistance from others, when turning the assembly over and laying horizontally, ensure that you have supports of sufficient height so that the TD arm does not get damaged.
- 19.3.14 Alternatively you can stand the damper up vertically, but you will need wooden blocks to sit the case onto so that the AF fixing frame does not get damaged.
- 19.3.15 Once the part completed assembly is stable and supported, you can now affix the front joining channels. Once complete do check the assumed spigot size complies.
- 19.3.16 Drill out the inner row of 2mm diameter angle frame pilot holes on the AF installation frame. Where the assembly is made up from four sections, each damper will have two sides only with the AF frame fitted. Where the assembly is made up from six sections or more, then the four end dampers (two each end) will have two sides with AF fixing frame and the centre dampers with only a single side having the AF fixing frame.
- 19.3.17 Position the previously prepared 10mm spacing blocks evenly within the opening and stand the damper on the spacing blocks so that damper is central in the opening, with the blades running horizontally.
- 19.3.18 Using the inner row of pilot holes, screw the EASY FIX® angle frame to the wall using drywall screws at 150mm Max pitch picking up the track lining the hole.
- 19.3.19 There is no requirement to fit a pattress on the reverse side of the damper or fill the void between the damper case and prepared aperture.
- 19.3.20 The damper assembly AF fixing frame should be fitted flat to the dry line wall with no gaps.

19.4 Thermal Fuse Installation

- 19.4.1 Where connecting ductwork is installed fit the thermal fuse into position using the template provided referring to section 23 on page 20 for positioning.
- 19.4.2 Where ductwork has not been connected, ensure that the thermal fuse is not left hanging by the connecting lead. It should be stored in a way that allows the thermal fuse probe to be protected prior to being fitted. It is recommended that the actuator packaging that also houses the thermal fuse during transportation, is left in situ until the connecting ductwork has been installed.

Masonry Wall & FC Installation Method

20. AF Fixing Frame Installation (Refer to M10 MULTI)

20.1 The principal of installation within a masonry wall will be the same as given above with exception of the following:-

- 20.1.1 The prepared masonry aperture must not be oversized and the dimensional details over and above the assembled case sizes must be observed.
- 20.1.2 Using the outer row of pilot holes, screw the EASY FIX® angle frame to the wall using drywall screws at 150mm Max pitch.

21. Masonry Floor Installation Method

21.1 Important Information

- 21.1.1 The assembly of multiple dampers will require a minimum of two persons.
- 21.1.2 The preparation of apertures for Dampers with multiple sections follow the same principals as a single section installation.
- 21.1.3 The finished aperture size should have an allowance of 10mm between the damper perimeter case and the finished aperture size top and bottom and an allowance of 35mm on the left and right hand sides between the damper case and finished aperture size.

21.2 Preparing the Aperture

- 21.2.1 Make sure that the intended position of the damper can be achieved observing the minimum separation dimension between the assembled fire damper and construction elements. Refer to 8.2 on page 5. Other services should not share the same opening as the installed damper assembly. Mark out the position and size of the required cut size on the floor. Using appropriate means. It is important not to oversize the aperture and any precast apertures take into account of the required finished aperture.
- 21.2.2 The damper must be affixed to the top of the floor via the AF fixing frame and with the damper body within the floor.
- 21.2.3 The damper will require a 500mm long section of ductwork to allow the additional support to be affixed. This section should be formed from 1.2mm galvanised steel and fitted to the rear perimeter of the damper spigots using 4.8mm diameter x 8mm steel rivets at 50mm centres.
- 21.2.4 The additional support is provided by M12 studs attached near the centre of the assembly suspended from a steel channel above the assembly. See drawing FSD-TD M11 MULTI.
- 21.2.5 Please refer to drawings FSD-TD M11 MULTI for installation details.

21.3 Flexible Curtain Installation Method. (Refer to FSD-TD M14)

- 21.3.1 Parts required and checks.
 - 21.3.1.1 Damper.
 - 21.3.1.2 Two pairs of clamp plates attached to each damper.
 - 21.3.1.3 ST4.8mm dia x19mm long safety self-tapping blunt point (qty to suit damper size).
These are optional accessories at time of purchase of dampers.
- 21.3.2 Prepare and install damper into position.
 - 21.3.2.1 Remove clamp plates from the damper. The clamp plates (1pair – top/bottom and 1pair - sides).

Clamp plates will be screwed in corners of the damper frame for transportation, thus aids in identification of sides and tops/bottoms. Where damper W+H are very similar, its important you note which plates are tops/bottoms and which plates are sides.
 - 21.3.2.2 One pair of M10 threaded drop rods are required to be suitably fixed to structure to hang vertically in a fire safe manner to fully support the weight of the damper. There is no limit on drop rodlength.
 - 21.3.2.3 To ease install, the drop rods can be joined using a coupling nut and pair of lock nuts to save having to spin the M10 nuts all the way along the length of the studding to the top cleat. i.e.:-

- 21.3.2.4 Upper drop rod length – The end should be ~100mm below the top damper cleats.
 - 21.3.2.5 Lower drop rod end should be ~50mm below the bottom damper cleats.
 - 21.3.2.6 Fix drop rod structure fixings in position to allow the drop rods be positioned at a distance apart to match the pitch between the welded cleats either side of damper.
 - 21.3.2.7 Measure required length of upper drop rods as described above, cut to length.
 - 21.3.2.8 Fit top drop rods into structure fixings.
 - 21.3.2.9 Position damper by passing the top cleats through the two drop rods, and fitting a pair of M10 nuts to each drop rod underneath the cleats. Ensure damper is horizontal and at required height by rotating the nuts as required.
 - 21.3.2.10 Fully tighten structure fixings/drop rods and also each pair of cleat nuts to lock in position.
 - 21.3.2.11 Measure required length of lower drop rods as described above, cut to length.
 - 21.3.2.12 Pass the lower drop rods through bottom damper cleats and join to upper drop rods with coupling nut and lock nuts as view C of installation drwg
 - 21.3.2.13 Fit a pair of M10 nuts to each lower drop rod underneath the damper bottom cleats as per installation drwg. Rotate and lock the nuts so that damper weight is equally shared across all four cleats, adjusting as necessary.
 - 21.3.2.14 Fully tighten both bottom nut pairs.
 - 21.3.2.15 Check all structure fixings and studding nuts are tight and secure.
 - 21.3.2.16 Test damper for operation – refer to section within IO+M.
- 21.3.3 Install FFC material around damper
- 21.3.3.1 Referring to Firefly Installation guide (www.tbafirefly.com/fire-barriers/), decide where the FFC material vertical joints will need to be positioned. Its important not to have a joint close (within 100mm) to either side of the damper frame sides. For small dampers, it may be possible that no joint is necessary between the cleats depending on the overall wall dimensions and damper position.
 - 21.3.3.2 Fit fire curtain vertical lengths either side of damper.
 - 21.3.3.3 Measure damper spigot position within structure and mark on the fire curtain where the cut opening is to be located, allowing for extra FFC material as necessary to attach to structure/overlap joints.
 - 21.3.3.4 Finished opening cut size should be the damper spigot size. Any excess can be left as ‘wrapping around’ the spigot.
 - 21.3.3.5 Cut opening in the FFC material to allow material to pass over damper spigot. It is advisable to cut ‘a cross’ diagonally from centre of spigot to the four corners only at this stage, and cut to final size once FFC material is fixed to structure /adjacent fire curtain vertical runs.
 - 21.3.3.6 Install FFC material to structure and if applicable, overlap butt joints to adjacent FFC material run
 - 21.3.3.7 Cut opening/trim FFC material to spigot size with a plus 10mm tolerance for each of the spigot sides.
 - 21.3.3.8 Locate top clamp plate in position sandwiching the FFC material. Screw to damper frame by piercing FFC material and ST4.8x19 safety self-tapping screws but leave loose until all four clamp plates are fitted. 21.3.3.9 Repeat with bottom clamp plate.
 - 21.3.3.10 Finally, fit both side clamp plates passing through the corner holes of the top/bottom clamp plates.
 - 21.3.3.11 Tighten all screws to securely sandwich the FFC material.
 - 21.3.3.12 If necessary for aesthetic purposes only, trim any excess FFC material protruding near the spigot.
 - 21.3.3.13 Wrap Penowrap around the entire length of the drop rods as per Installation drawing keeping as close to the structure fixings and cleats as possible. Secure in place using steel cable ties (250-300mm pitch).
 - 21.3.3.14 Check damper perimeter that FFC material is intact and that no gaps/ cuts or tears exist and that the overlapping butt joints and fixing to structure remain intact.
 - 21.3.3.15 Fit ductwork in accordance with DW145, using breakaway joints (aluminium rivets) and ensure ductwork is independently supported.
 - 21.3.3.16 Continue with testing and commissioning as detailed in Section 25.

21.4 Thermal Fuse Installation

- 21.4.1 Where connecting ductwork is installed fit the thermal fuse into position using the template provided referring to section 23 on page 18 for positioning.
- 21.4.2 Where ductwork has not been connected, ensure that the thermal fuse is not left hanging by the connecting lead. It should be stored in a way that allows the thermal fuse probe to be protected prior to being fitted. It is recommended that the actuator packaging that also houses the thermal fuse during transportation, is left in situ until the connecting ductwork has been installed.

Actuator and Thermal Fuse

22. Actuator

22.1 Important Information

- 22.1.1 Do not remove the factory fitted actuator. Removal of the actuator without first seeking approval from BSB will invalidate the warranty and guarantee.
- 22.1.2 Actuators are available as 24 volt AC/DC or 230 volt AC spring return. Check that you have the correct voltage before making any connections.
- 22.1.3 Actuators are fitted to the 12mm A/F square shaft on the Transfer Drive (TD) box via a single bolt. The actuator sits onto a shoe bracket for stability.
- 22.1.4 Check that the actuator, thermal fuse, and cables are undamaged.
- 22.1.5 Do not cut the thermal fuse cable under any circumstances.
- 22.1.6 Check the actuator label for correct voltage and operation.
- 22.1.7 Actuator action is fail-safe spring closed.

22.2 Wiring Instruction

- 22.2.1 The actuator comes complete with three cables pre-wired at the factory. The actuator is designed not to be opened.
- 22.2.2 The power cable exits above the thermal fuse cable and consists of two wires, live and neutral.
- 22.2.3 The indication cable has six wires and indicate the damper positions open and closed.
- 22.2.4 Wiring diagram Fig. 10 confirms the connections.

23. Thermal Fuse (TF)

23.1 Fitting Information

- 23.1.1 The thermal fuse self-adhesive template supplied should be positioned on the ductwork above the top line of the actuator.
- 23.1.2 For round ducts, the three drilled holes must be in-line with the duct axis. For ductless applications, a TF bracket is available from BSB and can be fixed to the damper spigot.
- 23.1.3 Drill holes in duct (sizes/positions are detailed on template label Fig. 11 and remove burrs).
- 23.1.4 Fit the TF to the duct with the two screws provided using Philips No.2 screwdriver/bit.
- 23.1.5 Once the thermal fuse has been installed and power connected, the damper blades will begin to drive open. Once fully open the green LED on the thermal fuse head will illuminate. This confirms that the damper has fully reached the open position and there is a supply voltage.
- 23.1.6 Depressing the test button continuously on the head will allow the damper to spring closed. This is momentary switch and once you have removed your finger, will allow the damper to re-open.

Fig. 10

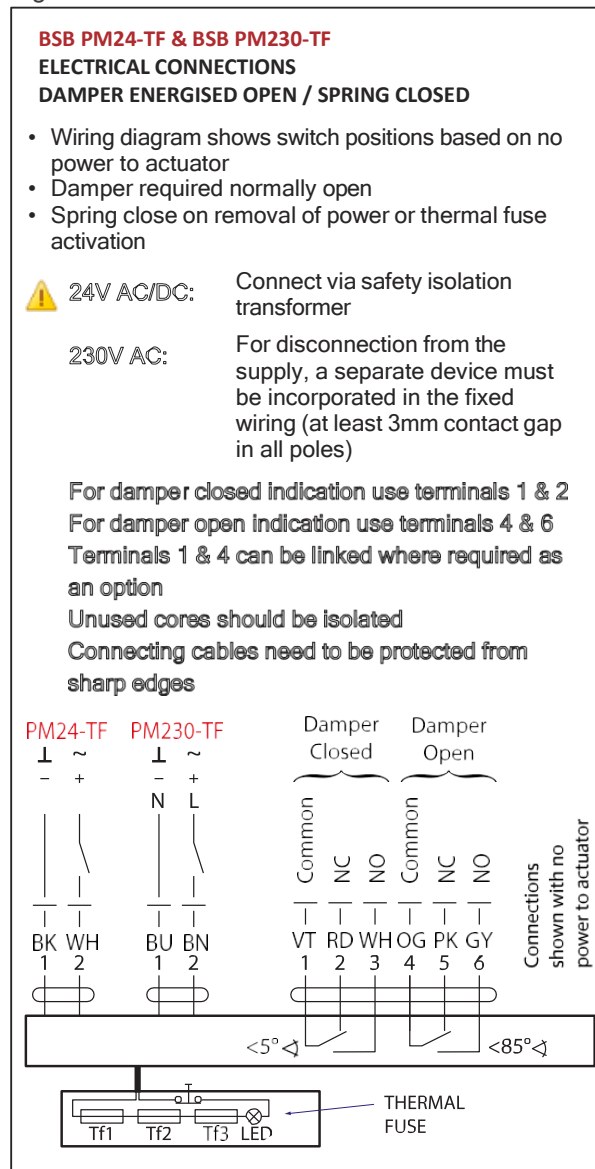
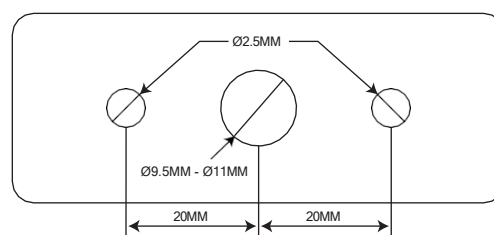

Fig. 11 THERMAL FUSE DRILLING TEMPLATE



24. When Power is not Available

- 24.1 Dampers can be manually wound open to allow duct work systems to be tested where power is not available to the actuator. Manually wind the actuator, using the crank handle (provided) fully to the 'reset open' position, and lock into position by turning the key in reverse sharply a quarter turn. (Due care should be taken to stop winding when slight resistance is encountered - over-winding can result in permanent damage to the damper/actuator which may invalidate the warranty). It is important that you only use the manual winding key provided. The use of a powered drill or screwdriver is not permitted.
- 24.2 Release the motor if it is locked by turning the crank handle a quarter turn in the winding direction and allow the damper to spring close to 'fail-safe' position.

25. Routine Inspection, Testing and Maintenance

25.1 Routine Inspection

- 25.1.1 In accordance with BS 9999 Annex W.1, inspection should be undertaken annually. Local regulations/conditions may override this with periodic inspection being carried out more frequently where corrosive or dirty conditions prevail. The maintenance log should be reviewed at each inspection and the frequency adjusted as required dependent upon findings.
- 25.1.2 BSB recommend a maximum of 1 year between inspections and to start more frequently initially and reduce frequencies only if conditions are proven to allow.
- 25.1.3 Visually check that the damper is in its 'powered state' (opposite to fail-safe position). If the damper is not in its 'powered state', refer to fault finding chart, otherwise continue.
- 25.1.4 Visually inspect the internal damper elements for signs of corrosion, obstruction or accumulated dirt/dust.
- 25.1.5 Check that the blades are not obstructed from fully operating by debris or alien objects.

25.2 Testing

- 25.2.1 Check that the LED on the thermal fuse is illuminated. This will confirm that power is present and operational. If it is not illuminated, see "Fault Finding" on page 22.
- 25.2.2 Temporarily remove electrical power to the actuator (either by using the test switch on the thermal fuse, or by isolating power to actuators). The actuator should now release spring closed. Check that the damper has fully closed before allowing the blades to reset.
- 25.2.3 Check that the blades have reset to the fully open position.
- 25.2.4 If the blades do not move smoothly or fail to reach either end of travel, refer to the fault finding section.

25.3 Maintenance

- 25.3.1 Spray a light lubricant into the blade end bearings through the holes on the side gasket. Wipe the internal surfaces with a soft oiled cloth leaving a thin layer of oil. Excess oil should be wiped away.
- 25.3.2 Record all work that has been undertaken in the maintenance log including any remedial works.
- 25.3.3 It is important to log and review maintenance frequency based on inspections and test history.

Fig. 12

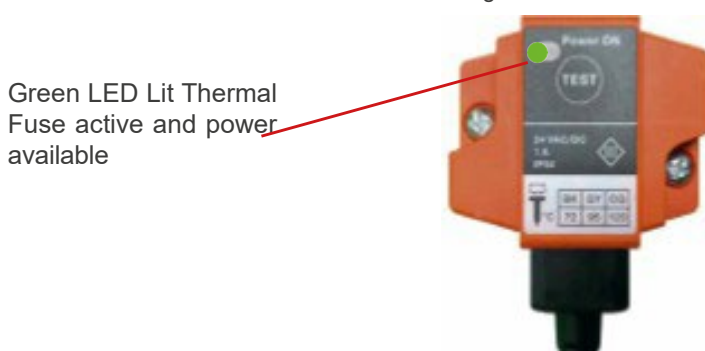

25.4 Actuator Access/Maintenance/Install zone

25.4.1 Leave enough space to access requirement for remove and re-fitting of actuator. See red areas shown below.

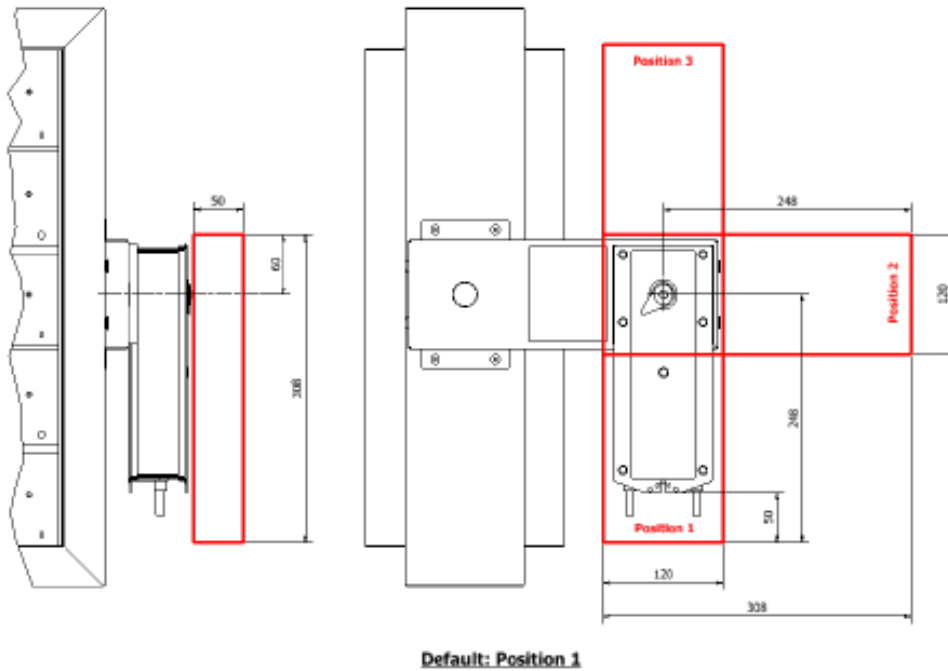

Fault Finding

Symptom	Fault	Action
Green LED on the Thermal Fuse (TF) is not illuminated.	No power / incorrect supply.	Check supply.
	TF tripped.	Remove TF from duct, separate two halves, continuity check the two contacts with the probe section (or test with new probe). If open circuit, replace probe.
	Actuator faulty.	Replace actuator
Blades do not travel fully open/closed.	Synchronisation of actuator and damper incorrect.	Remove actuator and refit.
	Debris or other foreign matter impeding blade operation.	Inspect blades for damage or where obstruction is present and remove carefully. Check Operation.
	Damper seized.	Contact BSB Sales Office T: +44 (0)1795 422 609 E: technical@bsb-dampers.co.uk
Noisy damper during operation.	Lack of maintenance to the blade bearings.	Apply DEB duck oil or similar to the side gasket and blade bearing. Then wipe away any dirt/dust with a soft cloth.

Damper Installation Certificate

Project Name: Date of Installation:.....

Installation Address Postcode:

Location Identification (Section/Floor/Room):

The installer should complete this installation certificate when installing BSB Engineering dampers. A separate certificate must be completed for each individual damper. This certificate applies only to BSB Engineering dampers.

No.	Questions	Guidelines	Confirmed
1.	Are the dampers the correct type?	Confirm the damper is the correct type and model	YES / NO
2.	Are the dampers correctly identified individually?	Unique system identification and location reference aids commissioning and must be clearly indicated on the damper or agreed location	YES / NO
3.	Are the dampers located correctly?	The damper position shall be checked against the installation drawings and/or instructions	YES / NO
4.	Is the installation method tested and approved for the type of barrier that is being protected?	Ensure modifications have not been made to the tested method	YES / NO
5.	Is the damper installed and fixed in accordance with the manufacturer's tested and approved methods?	Check the damper has been fixed correctly to the fire barrier and is independently supported from the ductwork	YES / NO
6.	Have access doors been fitted to the ductwork allowing the damper blades to be inspected?	Access doors are required for commissioning and servicing	YES / NO
7.	Is access through the ductwork to the damper unhindered?	Unobstructed space shall be provided for safe access to damper. Also consider access through ceiling's voids and adjacent service	YES / NO
8.	Is penetration only used by the damper and not used for the passage of other services?	The presence of other services will invalidate the approved installation method	YES / NO
9.	Using the access opening provide, has the damper been left in the open position?	Check blade position	YES / NO
10.	If motorised, is the correct power supply wired to the actuator and power is on?	Check power is on to the actuated damper, to ensure testing can be carried out	YES / NO
11.	Is the Thermal Fuse or Link correctly installed?	Confirm fitted correctly to ductwork/damper	YES / NO
12.	Have the damper blades been released to simulate failure of thermal release mechanism (damper 'drop test')?	Test button on thermal fuse probe shall be used or fusible link removed to drop test	YES / NO
13.	Have the dampers been checked for internal cleanliness free from damage and debris?	With the damper in the closed position inspect for damage and contamination	YES / NO
14.	Have the dampers blades been re-set following the drop test and the access panel replaced?	Damper installer to record, on the register, any incomplete works relevant to the damper installation	YES / NO
15.	At the time of the damper handover, is fire damper installation completed in accordance with this check list?	Damper Installer to record, on the register, any incomplete works relevant to the damper installation	YES / NO
16.	Is the damper installation completed and available for handover prior to system commissioning?	Obtain relevant acceptance of the damper installation from the system designer	YES / NO
17.	Is the completed handover register cross referenced back to the identification codes listed in the system		YES / NO

Damper reference ID: Damper product type:

Notes/Considerations (Please use an additional sheet if applicable):

Company name:

Company address: Postcode:

Company telephone: Company website:

Installer's first name: Installer's Last name:

Installer's mobile:..... Email address :

Please provide the full name, contact number and email address of additional installers on a separate sheet.

I, the undersigned, confirm that the damper referenced in this certificate has been checked and installed to the manufacturer's tested method.

Signature: Name: Date:

FSD-TD Series

Installation, Operation and Maintenance Instructions



A brand of
MAICO

Other Air, Fire and Smoke Control Products in the BSB Range:



For full details of the complete BSB Product Range, please refer to our individual product brochures, sales office or website.



A brand of
MAICO

BSB Engineering Services Limited

Unit 56, Trinity Trade Centre, Mill Way, Sittingbourne, Kent ME10 2PD, UK • Tel: +44 (0)1795 422609

For purchase orders and order related enquiries, please email: orders@bsb-dampers.co.uk

For pricing, technical and general enquiries, please email: enquiries@bsb-dampers.co.uk

Website: www.bsb-dampers.co.uk • A member of the Maico group

BSB Engineering Services Ltd. reserves the right to modify or withdraw any specification without prior notice that may result from continuous product development. The information contained within this brochure is correct at the time of going to press.

