

FSD-C Series



Installation, Operation and Maintenance Instructions

THESE INSTALLATION INSTRUCTIONS MUST BE READ IN THEIR ENTIRETY BEFORE COMMENCING WORK TO ENSURE COMPLIANCE

Dampers will only be CE marked if:

- Installed as tested
- These instructions are followed

Any non-tested proposals cannot be CE marked.

Before commencing installation, the "Installation Check List" within DW/145 should be referred to. See "Damper Installation Certificate" on page 14.



A brand of
MAICO



MANUFACTURERS OF AIR, FIRE AND SMOKE CONTROL PRODUCTS



FSD-C Damper Installation, Operating & Maintenance Instructions

Storage

Dampers received on site should be stored in a purpose made storage area, where they can be protected from moisture, dust, and impact damage until required. Dampers are designed for installation within internal normal dry filtered H&V systems.

1 Health and Safety

- 1.1 Only competent personnel may carry out the work outlined in this document.
- 1.2 Wear appropriate Personal Protective Equipment as required for safe working conditions and as site rules dictate.
- 1.3 Do not introduce fingers across the open blade.
- 1.4 Where dampers are only accessible with the need for additional elevation, any equipment used should be done so with due consideration to the Work at Height regulations 2005 and current site rules.

2 Important

- 2.1 These instructions should be read in its entirety before commencing work. The installer must be Competent with the manufacturer's separating element construction.
- 2.2 PML Actuators are IP54 rated – Check actuator connection box is suitably located.
- 2.3 Do not cut/shorten the Thermal Fuse lead (-TF Actuators). This will render the unit inoperable and invalidate the warranty.
- 2.4 Refer to actuator label section 10 for wiring of actuator.
- 2.5 Refer to section 12 for testing.
- 2.6 For existing dry walls – When cutting the opening for damper, and (partial) removal of stud is unavoidable, ensure the structure is sufficiently supported to conform to design specification.
- 2.7 Dry wall openings must be lined.
- 2.8 Ensure that appropriate 'fire-rated' plasterboard is used throughout the construction of drywall partitions that need to act as fire-barriers.
- 2.9 Ductwork to be fitted and connected in accordance with DW 144/145. Aluminum rivets should be used (to act as breakaway joint).
- 2.10 All installations are subject to local Building Control Approval (BCA). Tested Installations are detailed herein. If the proposed installation has minor variations to that shown, acceptance from BCA should be sought before proceeding. Manufacturers are not able to 'approve' specific installation methods.

3 Equipment required

- 3.1 Equipment and tools will vary dependent upon the fire barrier construction that the damper is being installed within. Standard equipment that are normally used for the building of the particular barrier should suffice. Access-equipment as necessary.
- 3.2 8mm, 10mm for motor fixing to adjust blade position via drive shaft. 2.5 AF allen key for setting of mid-set position if required. Cordless drill
- 3.3 Screwdriver to suit junction box terminals.

4 Preparation for Installation and General notes

- 4.1 Before installation, the damper should be inspected to ensure that it has not been
- 4.2 damaged and is in good condition following transportation/on site storage.
- 4.3 Check damper reference and size to site specification.
Install damper to site specification details and building codes of practice. (Refer to Tested Installation Methods). Non-tested installations may be rejected by
- 4.4 building control.
- 4.5 Ensure that the ductwork is independently and adequately supported.
- 4.6 Note: All Fire / Smoke Damper installations must be carried out to the satisfaction of the appropriate Building Control officer and/or specifying authority. Where more than one duct penetrates a wall or floor, a minimum of 75mm separation between fire damper and adjacent wall, floor or ceiling & 200mm between single section dampers. (to comply with BS EN1366-2 13.6).
- 4.7 Test damper (Refer to section 10)

Tested Installation Methods

5 Preparation

- 5.1 The installation method contained herein assumes the wall has been built prior to the damper opening preparation.
- 5.2 Determine required position of damper. Check sufficient space exists to fit the product (See section 11). Ensure any services (e.g. electrical/plumbing) within the structure or running close to the structure will not be affected. If existing stud/track is avoidable, ensure the structure is sufficiently supported to conform to design specification and that the opening is lined.
- 5.3 When the structure is deeper than 150mm it may be necessary to connect ducting to the non-access side of the damper through the opening, before final fitting the damper. Once this is done, slide the damper and ductwork assembly back through the opening until the Installation Plate is flat against the structural surface ready to be fixed.

6 Procedure

Dry wall Installation (Refer to MSD-C M9)

- 6.1 Preferably, prepare opening whilst building wall, or cut opening if wall already exists.

- 6.2 The opening must be 'lined out'.
- 6.3 Cut size = damper size + (2 x nominal gap size) + (2 x wall board thickness).
E.g. for 150mm dia. damper, and 12.5mm wall board, cut aperture should be 195mm (150+(2x10)+(2x12.5))
- 6.4 Mark out position and size of required cut size on the wall.

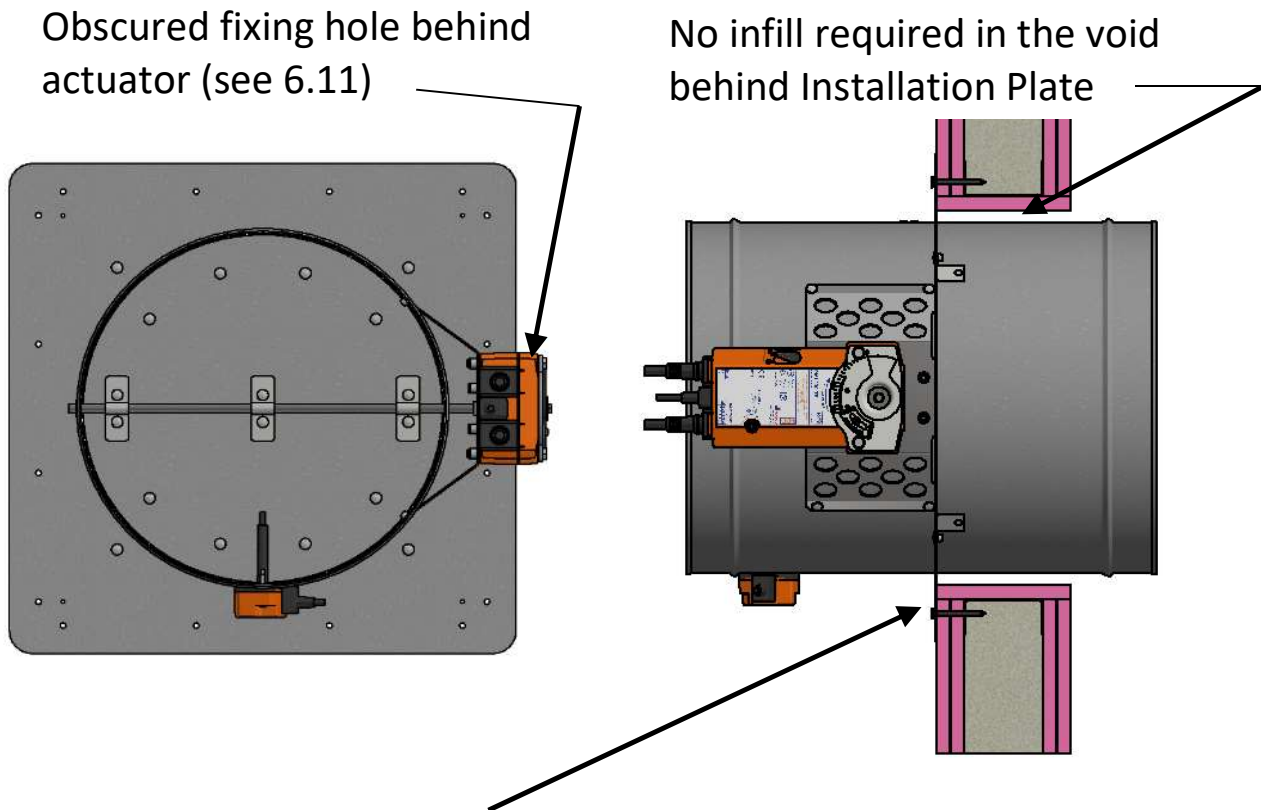

38mm long drywall screws to affix installation plate to metal frame within drywall (see 6.11)

- 6.5 Using appropriate means (e.g. jig saw), cut the aperture in the wall, removing each layer and any stud/track that is present
- 6.6 Cut 2 pieces of steel track 50mm+ longer than opening size.
- 6.7 Fit track to top and bottom of opening, screwing in position from both sides of wall at each end of track with drywall screws and at maximum 300mm centers.
- 6.8 Cut 2 more pieces of track, this time, equal opening size.
- 6.9 Fit track to sides of opening, screwing in position in a similar fashion as above.
- 6.10 Cut 4 pieces of dry wall material width to line the opening to the full width of the wall. Screw each baton with 2 screws to the track that is lining the opening.
- 6.11 Ensure the access side baton is flush with the surface of the wall. Position the damper centrally in wall opening (width/height), Using drywall screws, fix Installation Plate to wall using drywall screws. Important: Ensure the screws 'pick up' the track lining the aperture so that the proper fire integrity of the installation will not be compromised. Use either one of the two appropriate Ø5mm corner fixing holes and all Ø5mm mid-span fixing holes. Note for damper sizes of 100mm - 200mm dia, the mid span fixing behind the fitted actuator, can be omitted.

Masonry wall and floor installation (Refer to FSD-C M10)

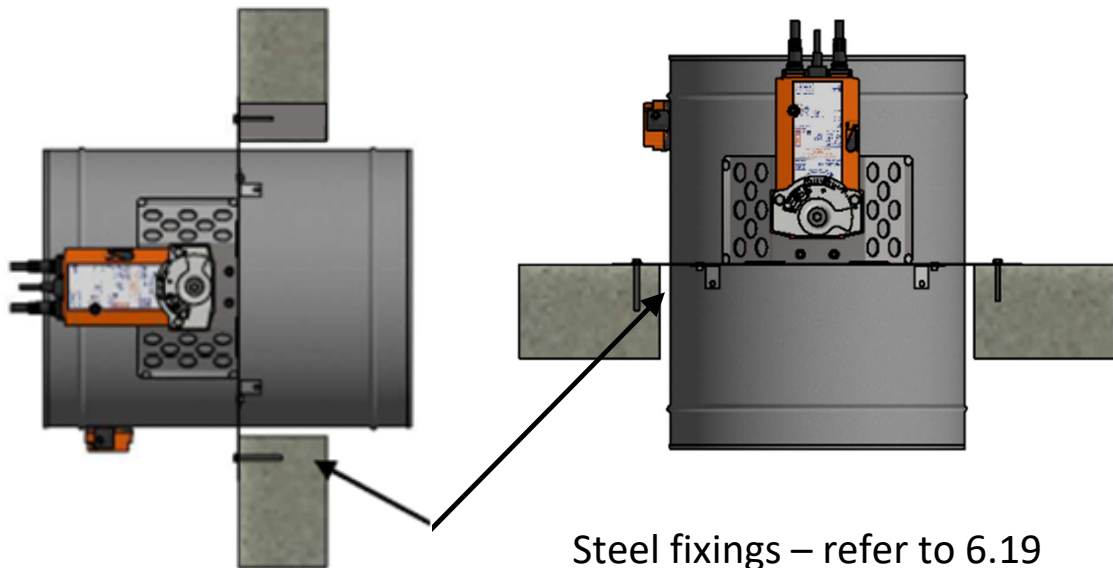

- 6.12 Preferably, prepare opening whilst building wall/floor, or cut opening if wall/floor already exists.
- 6.13 Cut size = finished size
- 6.14 E.g. for 250 dia. damper, cut aperture should be 270mm square (250+20)
- 6.15 Mark out the position and size of opening on the wall/floor.
- 6.16 Using appropriate means, cut the aperture in the wall/floor.
- 6.17 There are a variety of proprietary fixings available. Fixings must be fire rated (steel, NOT aluminum or plastic). Check minimum dimension specification between fixing and edge of opening. BSB recommend Tackburn Loden anchors.
- 6.18 Position the damper centrally in wall opening (width/height), with blade axle running horizontally. Using steel screws, fix Installation Plate to wall
Important: Use either one of the two appropriate Ø5mm corner fixing holes and all Ø5mm mid-span fixing holes. Note for damper sizes of 100mm – 200mm dia, the mid span fixing behind the fitted actuator, can be omitted.

7. Flexible Fire Curtain (FFC) installation method (Refer to FSD-C M14).

- 7.1 Parts required and checks.
 - 7.1.1 Damper.
 - 7.1.2 Clamp plate attached to damper.
 - 7.1.3 ST4.8mm dia x 19mm long safety self-tapping blunt point screws (quantity to suit damper size). These are optional accessories at the time of purchase of dampers.
- 7.2 Prepare and install damper into position.
 - 7.2.1 Remove the clamp plate from the damper. The clamp plate will be screwed in the corners of the damper frame for transportation.
 - 7.2.2 One pair of M10 threaded drop rods are required to be suitably fixed to the structure to hang vertically in a fire-safe manner to fully support the weight of the damper. There is no limit on drop rod length.

- 7.2.3 To ease the installation, the drop rods can be joined using a coupling nut and a pair of lock nuts to save having to spin the M10 nuts all the way along the length of the studding to the top cleat.
- 7.2.4 Upper drop rod length - The end should be approximately 100mm below the top damper cleats.
- 7.2.5 Lower drop rod end should be approximately 50mm below the bottom damper cleats.
- 7.2.6 Fix drop rod structure fixings in position to allow the drop rods to be positioned at a distance apart to match the pitch between the cleats on either side of the damper.
- 7.2.7 Measure the required length of upper drop rods as described above, cut to length.
- 7.2.8 Fit top drop rods into structure fixings.
- 7.2.9 Position damper by passing the top cleats through the two drop rods, and fitting a pair of M10 nuts to each drop rod underneath the cleats. Ensure damper is horizontal and at the required height by rotating the nuts as required.
- 7.2.10 Fully tighten structure fixings/drop rods and also each pair of cleat nuts to lock in position.
- 7.2.11 Measure the required length of lower drop rods as described above, cut to length.
- 7.2.12 Pass the lower drop rods through the bottom damper cleats and join to upper drop rods with a coupling nut and lock nuts as per view C of the installation drawing.
- 7.2.13 Fit a pair of M10 nuts to each lower drop rod underneath the damper bottom cleats as per view D of the installation drawing. Rotate and lock the nuts so that damper weight is equally shared across all four cleats, adjusting as necessary.
- 7.2.14 Fully tighten both bottom nut pairs.
- 7.2.15 Check all structure fixings and studding nuts are tight and secure.
- 7.2.16 Test damper for operation - refer to the section within IO+M.

7.3 Install FFC material around damper.

- 7.3.1 Referring to the Firefly Installation guide (www.tbafirefly.com/fire-barriers/), decide where the FFC material vertical joints will need to be positioned. It's important not to have a joint close (within 100mm) to either side of the damper frame sides. For small dampers, it may be possible that no joint is necessary between the cleats depending on the overall wall dimensions and damper position.
- 7.3.2 Fit fire curtain vertical lengths either side of damper.
- 7.3.3 Measure damper position within structure and mark on the fire curtain where the cut opening is to be located, allowing for extra FFC material as necessary to attach to the structure/overlap joints.
- 7.3.4 Finished opening cut size should be the damper size. Any excess can be left as 'wrapping around' the damper casing.

- 7.3.5 Cut opening in the FFC material to allow material to pass over damper spigot. It is advisable to cut 'a cross' diagonally from the centre of the damper to the inside of the damper case only at this stage, and cut to final size once FFC material is fixed to structure/adjacent fire curtain vertical runs.
- 7.3.6 Install FFC material to structure and, if applicable, overlap butt joints to adjacent FFC material run.
- 7.3.7 Cut opening/trim FFC material to damper size with a plus 10mm tolerance.
- 7.3.8 Locate the clamp plate in position sandwiching the FFC material. Screw to damper frame by piercing FFC material and ST4.8x19 safety self-tapping screws.
- 7.3.9 Tighten all screws to securely sandwich the FFC material.
- 7.3.10 If necessary for aesthetic purposes only, trim any excess FFC material protruding near the damper casing.
- 7.3.11 Wrap Penowrap around the entire length of the drop rods as per Installation drawing keeping as close to the structure fixings and cleats as possible. Secure in place using steel cable ties (250-300mm pitch).
- 7.3.12 Check damper perimeter that FFC material is intact and that no gaps/ cuts or tears exist and that the overlapping butt joints and fixing to structure remain intact.
- 7.3.13 Fit ductwork in accordance with DW145, using breakaway joints (aluminium rivets) and ensure ductwork is independently supported.
- 7.3.14 Continue with testing and commissioning as detailed in Section 12.

8 Actuator Orientation Change / Replacement

- 8.1 If required, the orientation may be changed to +90° or -90° from default 'in-line-with-duct'.
- 8.2 Ensure power to actuator is removed and allow actuator to travel to end position.
- 8.3 Unscrew the 8mm AF head screw (central motor retaining screw) and remove the set-point assembly.
- 8.4 Remove the 10mm AF head screws (motor body retaining bolts). (It may be necessary to partially wind the actuator a few degrees with the aid of the manual reset key to release residual torque).
- 8.5 Remove the actuator and refit in new position **without** changing the blade's position.
- 8.6 Secure with the 10mm AF head screws (5Nm), followed by the 'set point assembly' and 8mm AF head screw (3Nm).
- 8.7 Test (refer to section 12).

9 Setting of Damper mid set-point Position (optional)

- 9.1 Dampers are supplied with actuators set to travel to 'fully open' position by default.
- 9.2 Optionally, dampers can be set so that the 'open position' is restricted to between 30° to 90° (60° range). This is for system air balancing purposes, should it be required.
- 9.3 To utilise set-point positioning, temporarily release actuator (using 2.5mm AF allen key), unscrew and reposition the positional limiter engaging into the
- 9.4 2mm dia holes (as below).
Note: Wiring (section 9.5), If using "open damper status" indication.

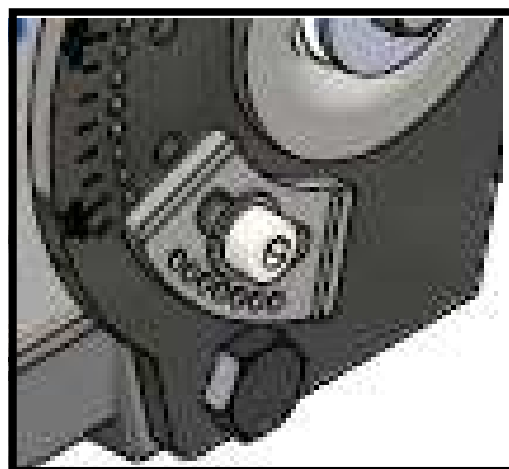
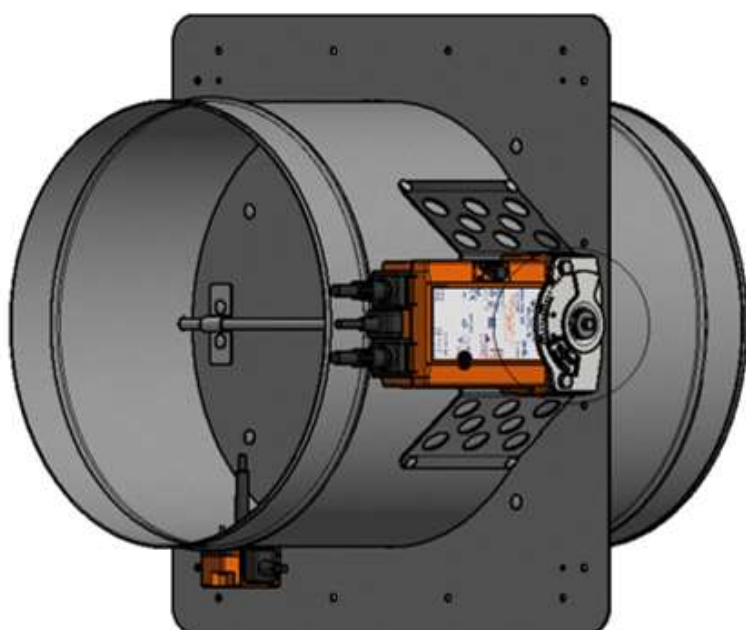

- 9.5 Retighten the retaining screw to approx. 3Nm.
- 9.6 Re-apply power and check desired open position is attained.

10 Wiring

- 10.1 Refer to electrical specification on back page of this document.
- 10.2 Dampers are supplied with actuators factory fitted and tested.
- 10.3 Connect wires in accordance with the wiring details below.
Test. (Refer to section 12)

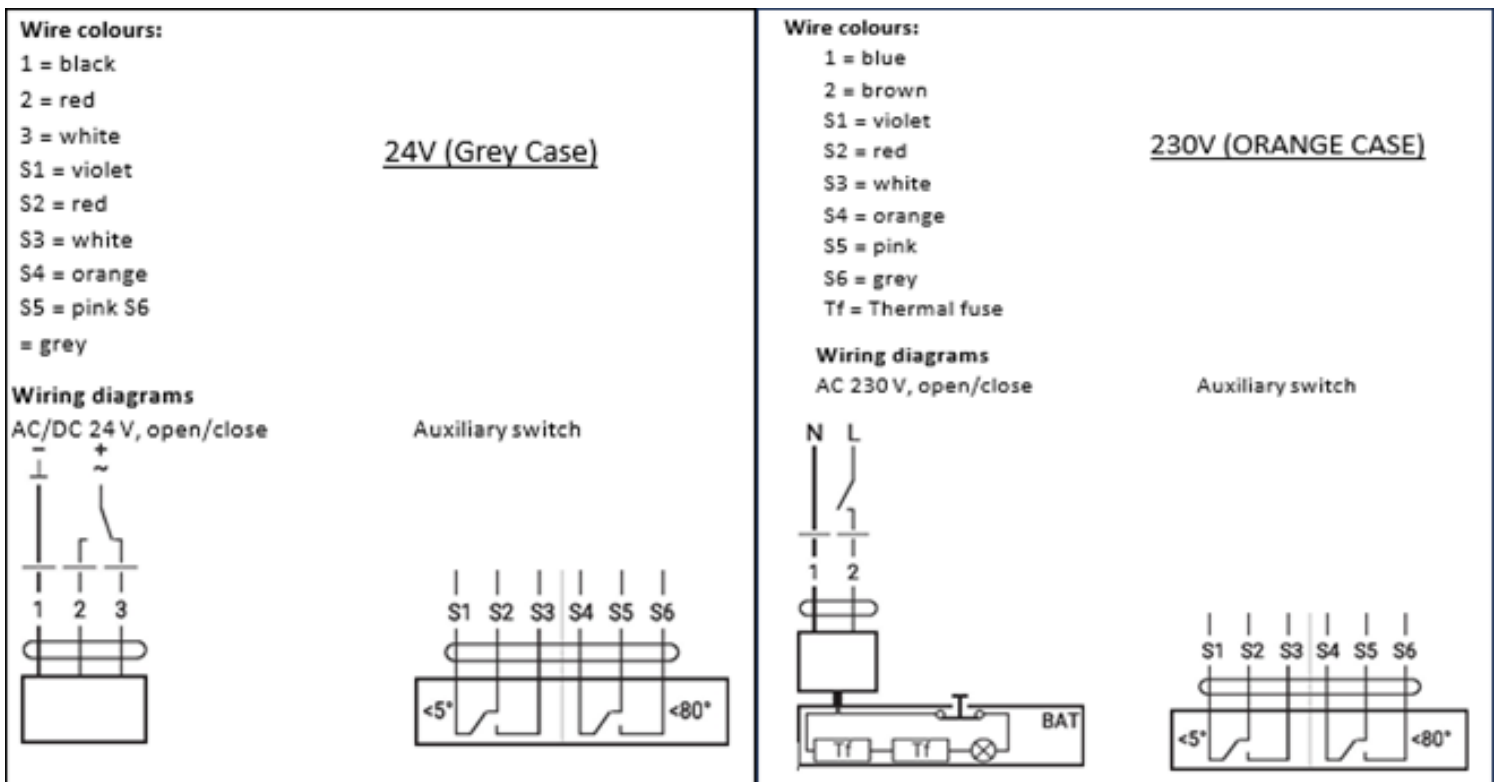

- 10.4 Make the following connections to achieve damper status indication:
 Closed - use 1&2
 open when not fully open - use 4&6
 open indication when mid set point function - use 1&3

11 Actuator and Thermal Fuse Access/Maintenance/Install zone

11.1 Leave enough room for removal and fitment of the actuator and thermal fuse. See red and blue zones below.

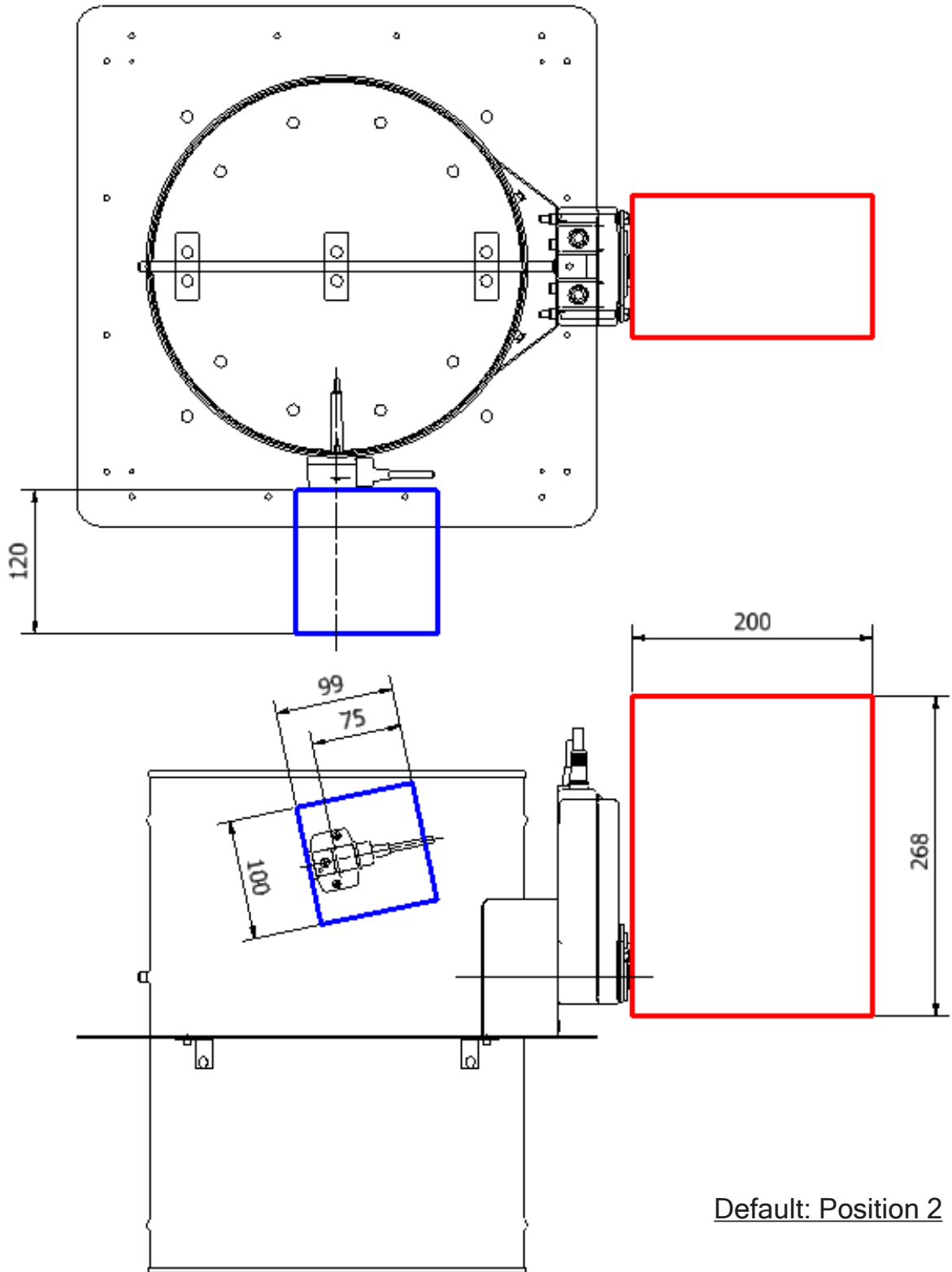

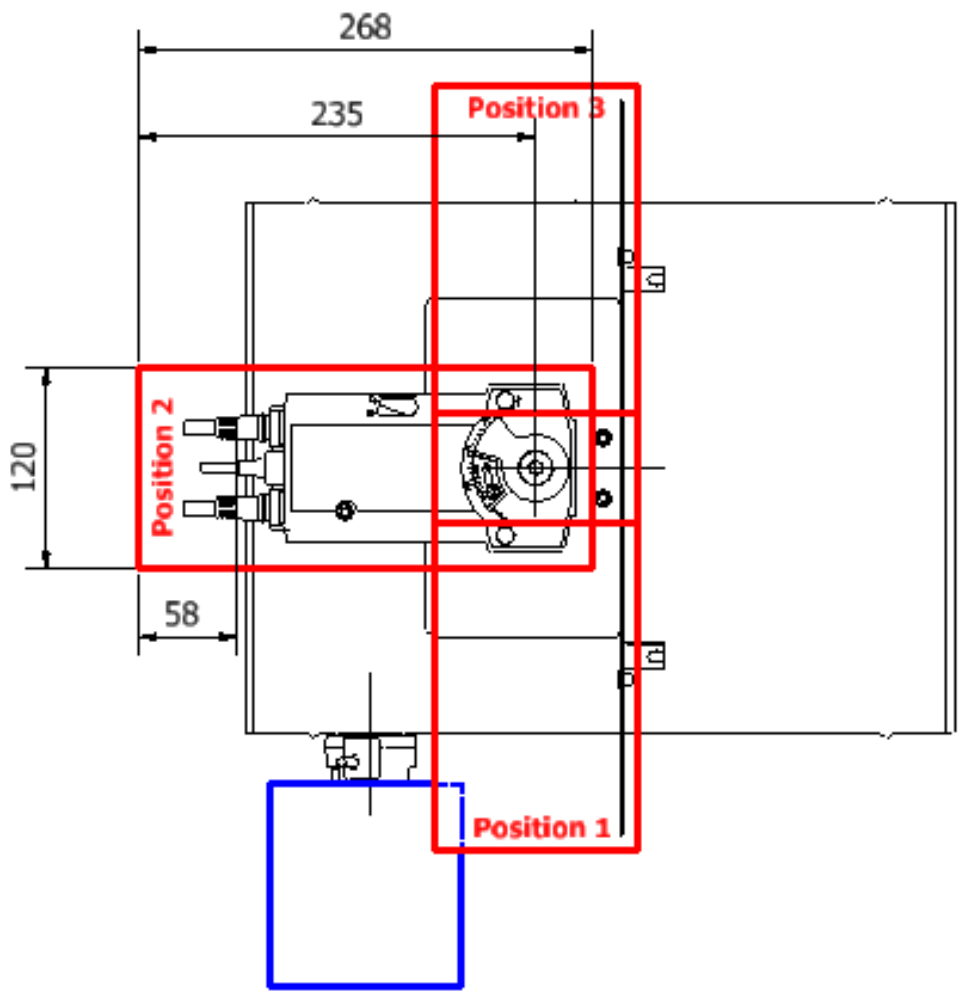

12 Commissioning, Maintenance and Test

- 12.1 Pre-check BEFORE power is established – Check the actuator voltage is suitable for the application. 24V has a grey case, 230V has an orange case.
- 12.2 In accordance with BS9999 Annex W.1, inspections should be undertaken at least annually, or more frequently where corrosive or dirty conditions prevail. The maintenance log should be reviewed at each inspection and the frequency adjusted as required dependent upon findings. (BSB also recommend a maximum of 1 year between inspections which should start more frequently initially and reduce frequencies only if conditions are proven to allow).
- 12.3 Check damper is in its 'normal state'.
- 12.4 If damper is not in its 'normal state', refer to fault finding chart otherwise continue.
- 12.5 As a pre-check BEFORE power is established – When the actuator orientation has been changed or the actuator has been replaced, it should be wound manually using the manual reset. If resistance is encountered – over-winding can result in permanent damage to the damper which may invalidate the warranty.
- 12.6 The actuator can be 'locked' open by winding manually with key provided, then locked and also released by rotating the black lever (next to the golden symbol) on face of actuator.
- 12.7 Switch to power to actuator. LED on TF will illuminate, and actuator will start on travel to DRIVE-END position. After 60 seconds, visually check that damper blade position and signaling corresponds.
- 12.8 **IMPORTANT:** Press and hold test switch button on the TF to allow damper to travel to its closed position. Visually check that the damper blade position and signal corresponds. (This is to ensure that the actuator functions electrically and overrides the manual reset facility, should it have been used, as it is feasible to leave the damper inadvertently reset without the TF being functional if this test is not carried out)
- 12.9 Release TF button to allow damper to drive to normal position.
- 12.10 If damper has seized – Open the damper (even partially if possible). Clean the inside of the damper case where the blade seals make contact. Use a soft cloth with a light application of light lubricant (Connect Duck Oil recommended). From the outside of the case, lightly apply a light lubricant into blade axle bearings. Remove excess lubricant.
- 12.11 It is important to log, and review maintenance frequency based on inspections and test history.
- 12.12 Use of heavy oils is not permitted, as this can lead to a build-up of dust/dirt on damper surfaces.
- 12.13 The PML actuator is maintenance-free.

12 Fault Finding

Symptom	Fault	Corrective Action
Damper not in its 'normal' state or Green LED on the Thermal Fuse (TF) is not illuminated	No power / incorrect supply	Check supply/terminations Check signal connections
	TF tripped. Remove TF from duct, separate two halves, continuity check the two contacts within the probe section (or test with new probe)	If open circuit, replace probe
	Actuator faulty	Replace
Damper does not travel fully open / closed	Damper seized(Check that the mid point function is not set)	Clean and lubricate. Operate manually a couple of times then remove any excess lubricant.
	Casing dented/damaged or not round	Minor damage may be corrected carefully with a mallet. (BSB always recommend replacement of damaged dampers)
	Foreign body interfering with blade sweep (commonly rivet or screw)	Inspect inside of damper case. Remove any offending item
Damper blade and/ or actuator does not move open	Damper internals have been exposed to excessive moisture	Gently apply pressure to blade by hand to move open. Use Scotch Bright pad RED 07447 grade, wet with duck oil and clean the damper internally at the point where the blade closes. Wipe dry and leave clean. 'Massage' exposed peripheral blade seal until pliable.
Report and log any damage found with actions to be taken.		

Electrical details

24V (Grey actuator case)

Nominal voltage	AC/DC 24 V
Nominal voltage frequency	50/60 Hz
Nominal voltage range	AC 19.2...28.8 V / DC 21.6...28.8 V
Power consumption in operation	4 W
Power consumption in rest position	1.4 W
Power consumption for wire sizing	6 VA
Power consumption for wire sizing note	I _{max} 8.3 A @ 5 ms
Auxiliary switch	2 x SPDT
Switching capacity auxiliary switch	1 mA...3 (0.5 inductive) A, AC 250 V
Switching points auxiliary switch	5° / 80°

230V (Orange actuator case)

Nominal voltage	AC 230 V
Nominal voltage frequency	50/60 Hz
Nominal voltage range	AC 198...264 V
Power consumption in operation	5 W
Power consumption in rest position	2.1 W
Power consumption for wire sizing	10 VA
Power consumption for wire sizing note	I _{max} 4 A @ 5 ms
Auxiliary switch	2 x SPDT
Switching capacity auxiliary switch	1 mA...3 (0.5 inductive) A, AC 250 V
Switching points auxiliary switch	5° / 80°

Damper Installation Certificate

DAMPER REFERENCE NO.:	DAMPER LOCATION:	
DAMPER SIZE: Dia (mm)		
WALL/FLOOR APERTURE SIZE ('OPENING SIZE')		
WIDTH	HEIGHT	
DAMPER INSTALLED BY:		
(Print name)		
Signature:	Company:	Date:
ACTUATOR ELECTRICALLY CONNECTED BY:		
(Print name)		
Signature:	Company:	Date:
Actuator mid-point setting (circle if applicable)		
30° 35° 40° 45° 50° 55° 60° 65° 70° 75° 80° 85° 90°		
FAIL-SAFE POSITION (POWER OFF position) – Tick appropriate		
Damper opens and closes fully (Electronically)	<input type="checkbox"/>	Indication Correct <input type="checkbox"/>
FINAL INSPECTION BY:		
(Print name)		
Signature:	Company:	Date:

Rev 3 March 2021	BSB Engineering Services Ltd Tel +44 (0)1795 422609
Email: enquiries@bsb-dampers.co.uk website: www.bsb-dampers.co.uk	

FSD-C Series

Installation, Operation and Maintenance Instructions



Other Air, Fire and Smoke Control Products in the BSB Range:



For full details of the complete BSB Product Range, please refer to our individual product brochures, sales office or website.



BSB Engineering Services Limited

Unit 56, Trinity Trade Centre, Mill Way, Sittingbourne, Kent ME10 2PD, UK • Tel: +44 (0)1795 422609

For purchase orders and order related enquiries, please email: orders@bsb-dampers.co.uk

For pricing, technical and general enquiries, please email: enquiries@bsb-dampers.co.uk

Website: www.bsb-dampers.co.uk • A member of the Maico group

BSB Engineering Services Ltd. reserves the right to modify or withdraw any specification without prior notice that may result from continuous product development. The information contained within this brochure is correct at the time of going to press.

