

FD Series

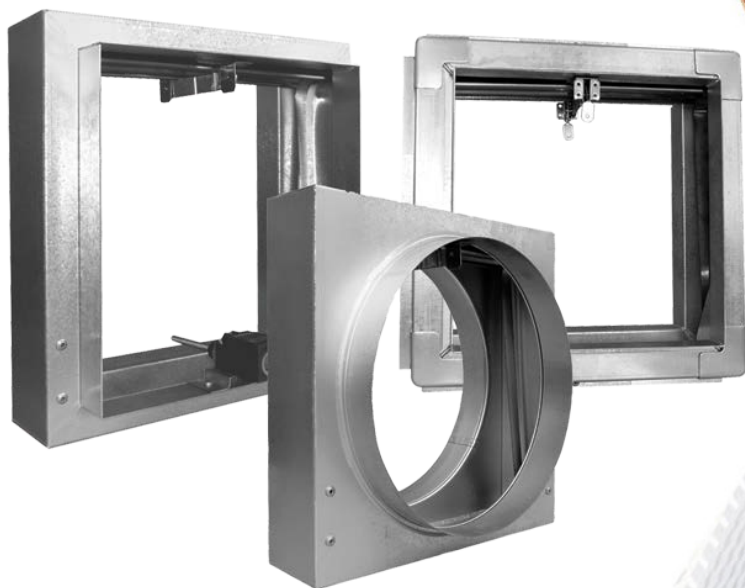

Installation, Operation and Maintenance Instructions

THESE INSTALLATION INSTRUCTIONS MUST BE READ IN THEIR ENTIRETY BEFORE COMMENCING WORK TO ENSURE COMPLIANCE

Dampers will only be CE marked if:

- Installed as tested
- No deviation to design
- These instructions are followed

Third party approval will be required for any non-tested proposal.

Before commencing installation, the "Installation Check List" within DW/145 should be referred to. See "Damper Installation Certificate" on page 16.



A brand of
MAICO



MANUFACTURERS OF AIR, FIRE AND SMOKE CONTROL PRODUCTS



FD Damper Installation, Operating and Maintenance Instructions

A brand of
MAICO

1 Storage

Dampers received on site should be stored in a purpose made storage area, where they can be protected from moisture, dust and impact damage until required.

2 Health and Safety

- 2.1 Only competent personnel may carry out the work outlined within this document.
- 2.2 The wearing of appropriate Personal Protective Equipment (gloves, footwear, safety glasses etc.) is required for safe working and as the site dictates.
- 2.3 Dampers may be heavy. Large dampers will require suitable lifting and supporting equipment, with due consideration given for manual handling.
- 2.4 Dampers may close without warning. Do not introduce limbs/fingers in the path of blade travel.
- 2.5 Never pull the side springs off their locking ramp pin. The springs are very strong and sharp and will damage fingers even when gloves are being worn!
- 2.6 All work should be carried out in accordance with HSE guidelines and regulations and any specific local site rules.

3 Important

- 3.1 These instructions should be read in its entirety before commencing work. The installer must be competent with the manufacturer's separating element construction.
- 3.2 All Fire Damper installations must be carried out to the satisfaction of the appropriate Building Control Officer and/or specifying authority.
- 3.3 Refer to section 13 for testing before installing. Complete Insp Check List (at end of this document).
- 3.4 For existing dry walls – When cutting the opening for damper, and (partial) removal of stud is unavoidable, ensure the structure is sufficiently supported to conform to design specification.
- 3.5 Dry wall openings must be lined.
- 3.6 Ensure that appropriate 'fire-rated' plasterboard is used throughout the construction of drywall partitions that need to act as fire-barriers.
- 3.7 Ductwork to be fitted and connected in accordance with DW 144/145. Aluminium rivets should be used (to act as breakaway joint).
- 3.8 All installations are subject to local Building Control Approval (BCA). Tested Installations are detailed herein. If the proposed installation has minor variations to that shown, acceptance from BCA should be sought before proceeding.
- 3.9 Manufacturers are not able to 'approve' specific installation methods.
- 3.10 Refer to main product brochure for full product details and specification. Where more than one duct penetrates a wall or floor, adjacent fire damper assemblies should be separated by a structural element with a minimum width of 200mm (to comply with BS EN1366-2 13.6).

3.11 Dampers need to be kept clean and dry, cement dust coming into contact with the closure springs should be avoided.

4 **Equipment required**

- 4.1 Equipment and tools will vary dependent upon the fire barrier construction that the damper is being installed within. Standard equipment that is normally used for the building of the particular barrier should suffice.
- 4.2 Access-equipment as necessary.
- 4.3 Temporary support equipment (to retain damper in position).

5 **Preparation for Installation**

- 5.1 For each damper installation type, refer to the relevant installation detail below.
- 5.2 Before installation, the damper should be inspected to ensure that it has not been damaged and is in good condition following site storage.
- 5.3 Remove packaging materials.
- 5.4 Check damper (label) reference, damper size, Fusible Link option and temperature to site specification.
- 5.5 Dampers are supplied in open position, with fusible link taped up with orange “remove before installation” tape. Remove this tape and drop test the damper (refer to section 13).
- 5.6 Determine required position of damper. Check sufficient space exists to fit the product. Ensure any services (e.g. electrical/plumbing) within the structure or running close to the structure will not be affected.
- 5.7 Consideration should be given beforehand, to the depth of the wall, relative to damper case length and connecting ductwork.

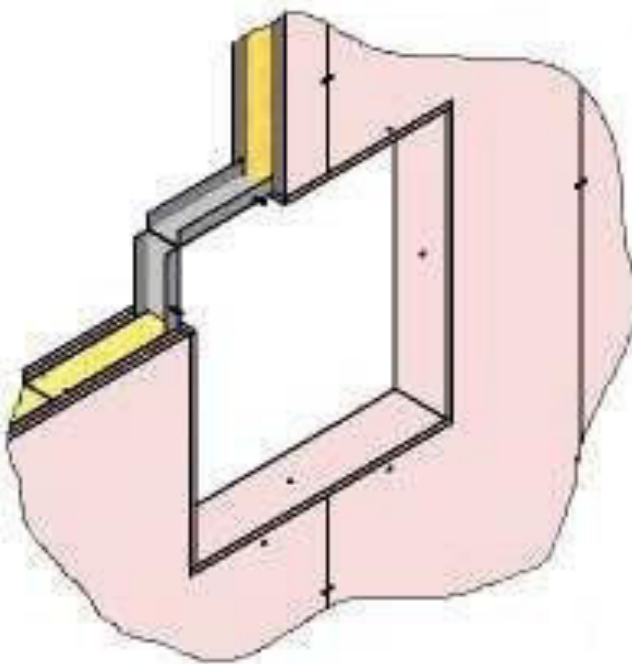

Figure 1 (Lined opening)

6 Dry wall preparation (see figure 1). Refer to FD M6 and M9 as appropriate

- 6.1 Preferably, prepare the opening whilst building wall, or cut opening if wall already exists. However, for cleated option, drop rods are required to be fitted prior to building the wall. Drop rods need to be sufficiently affixed to structure and be sized to cope with the damper's weight (refer to figure 13).
- 6.2 **Cleated and Frameless Installations.**
 - 6.2.1 The opening must be 'lined out' 10mm (+5mm) clearance top and bottom and 37mm maximum gap per side. (see fig 2).
 - 6.2.2 The cut size should be 74mm maximum (width), and 20mm (height) plus twice the wall board thickness above the overall damper's case size.
 - 6.2.3 Measure overall damper casing size. E.g. for a 755mm w x 825mm h overall case sized damper with 12.5mm wall board, the cut size should be 854×870 mm ($xxx + (2 \times 12.5) + 74$)w by ($yyy + (2 \times 12.5) + 20$)h.
- 6.3 **Angle Frame Installation size**
 - 6.3.1 The hole must be 'lined out' 10mm clearance all around.
 - 6.3.2 The cut size should be 20mm plus twice the wall board thickness above the overall damper case size.
 - 6.3.3 Measure overall damper casing size. E.g. for a 755mm w x 825mm h overall case sized damper with 12.5mm wall board, the cut size should be 800×870 mm ($xxx + (2 \times 12.5) + 20$)w by ($yyy + (2 \times 12.5) + 20$)h.
- 6.4 Mark out the position and size of required cut size on the wall.
- 6.5 Using appropriate means (e.g. jig saw), cut the hole in the wall, removing each layer and any infill that is present.
- 6.6 Cut 2 pieces of steel track equal to opening width.
- 6.7 Fit track to top and bottom of opening, screwing in position from both sides of wall at each end of track with drywall screws and at maximum 300mm centres.
- 6.8 Cut 2 more pieces of track, equal to the opening height.
- 6.9 Fit track to sides of opening, screwing in position in a similar manner as above.
- 6.10 Cut 4 'batons' of fire board to suit opening. Screw each baton with 25mm drywall screws @max 300mm pitch to the track that is lining the opening. Ensure batons are flush with the surfaces of the wall.

7 Dry wall – Pattress Fit and Cleated Damper – Fig. 2 (Refer to FD M6)

- 7.1 For wall thicknesses above 125mm, fit ductwork to damper prior to positioning damper within wall.
- 7.2 Prepare 16 off pattress pieces from plasterboard of same material as main construction. Plasterboard pattress should be sufficiently wide to butt up to damper spigots/duct and overlap the outer edge of the track lining the opening by at least 10mm. They need to be long enough to form neat corners.

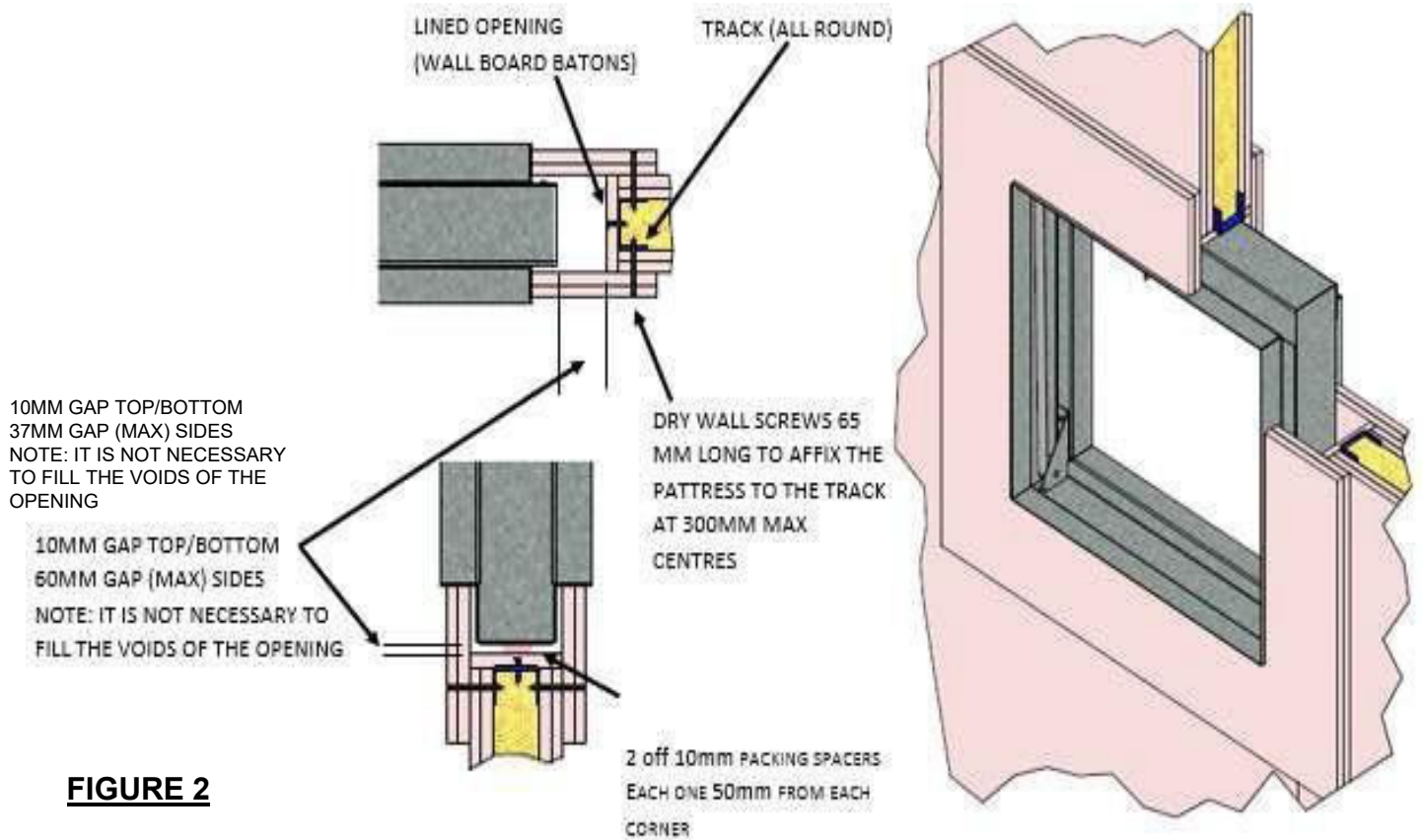

FIGURE 2

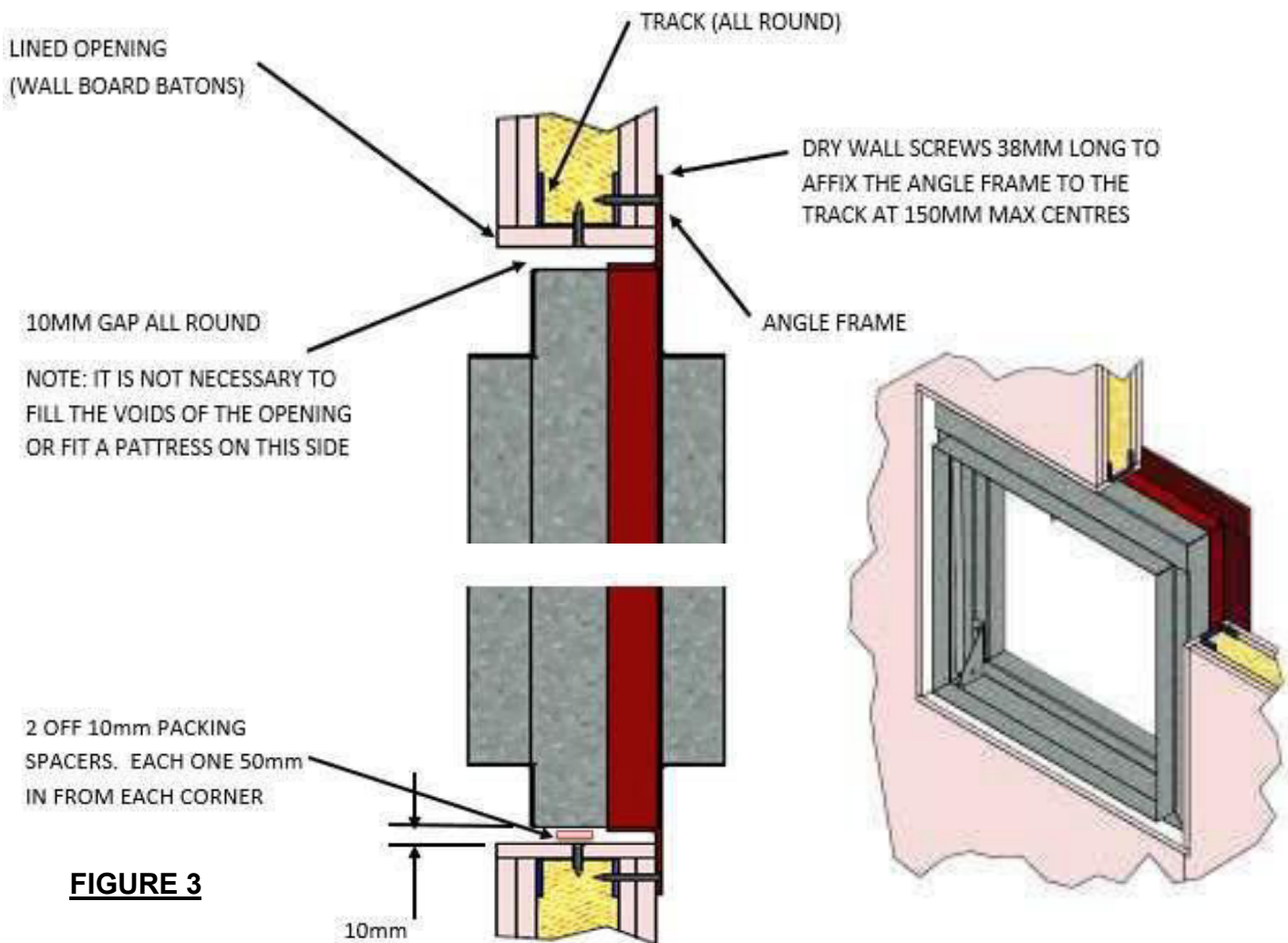

FIGURE 3

- 7.3 Position the damper centrally in wall opening (width/height), with blade pack at the top. To aid positioning vertically, position a pair of 10mm 'spacers' on the bottom of the opening 50mm from each corner to stand the damper on. Temporarily support damper. Fit ducting to damper. Use aluminium rivets to act as 'breakaway joints'.
- 7.4 Where cleats are fitted to the damper for support purposes (FD-CL), drop rods should be fitted. The table in figure 13 at end of this document, gives reference to sizing requirements of the threaded drop rods. Secure with a nut above and below the cleat.
- 7.5 Two layers of pattress are required each side of wall and the corners should 'overlap' between the first and second layers.
- 7.6 Dry wall screws of sufficient length to 'pick up' with the steel track within the wall, at 300mm max centres should be used to fix each layer of dry wall batons.
- 7.7 Apply intumescent sealant to the pattress parts and fit snugly up against the duct.
- 7.8 It is not a necessity to fill the void between pattresses.
- 7.9 Fit second pattress in similar manner to the first pattress.

8 Dry wall - Angle Frame Installation – Fig. 3 (Refer to FD M9)

- 8.1 Refer to section 6 for wall preparation instructions.
- 8.2 It is advisable to pre-drill the angle frame of the damper before fitting within opening. Note the position of the internal track in the wall and mark nominal hole fixing positions at 150mm maximum centres. Position the damper centrally in wall opening (width/height), with blade pack at the top. To aid positioning vertically, position a pair of 10mm 'spacers' on the bottom of the opening 50mm from each corner to stand the damper on.
- 8.3 Screw the angle frame to the wall using drywall screws @ 150mm max pitch.
- 8.4 It is not a necessity to fill the void behind the angle frame or fit a pattress on the non-access side.
- 8.5 Important: Ensure the screws 'pick up' the track lining the hole, so that the proper fire integrity of the installation will not be compromised.

9 HEVAC Frame Installation (wall and floor) – Figs 4-8 (Refer to FD M1 and M2 as appropriate)

- 9.1 Preferably, prepare opening whilst building the wall/floor (or cut an opening to the correct size if the wall/floor already exists).
- 9.2 Finished sizes should be 50mm min to 75mm max greater than HEVAC frame assembly extremities. The rougher the surface, the better for keying the mortar.
- 9.3 The damper is not load-bearing and additional support for the top of the wall opening is achieved by means of a lintel or other approved method.
- 9.4 Fit looped steel wall anchors (Ø5mm min) all round the inside of the opening in corresponding positions to the HEVAC frame builder's ties.
- 9.5 Bend the builder's ties out. (See Figs 7 & 8)
- 9.6 (Vertical installation only) Prepare a pair of spacing blocks, (approx. 25mm cubed) from any available material (such as drywall boards). Position spacing blocks within the opening at extremities of damper and stand the damper on blocks so that damper is central in opening.

- 9.7 While supporting the damper centrally in the cavity, secure the builders ties to the looped wall anchors with 1.5mm galvanized steel wire. (The loops must be tight and a minimum of 3 loops is recommended). (See Fig 7 & 8).
- 9.8 Fill the surrounding cavity with 4:1 builders sand/cement mortar and finish to desired standard

FIGURE 4

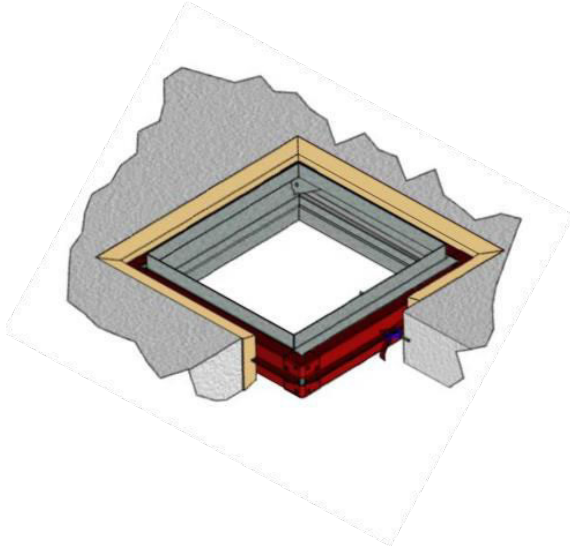

Access side. Locking ramps uppermost

FIGURE 5

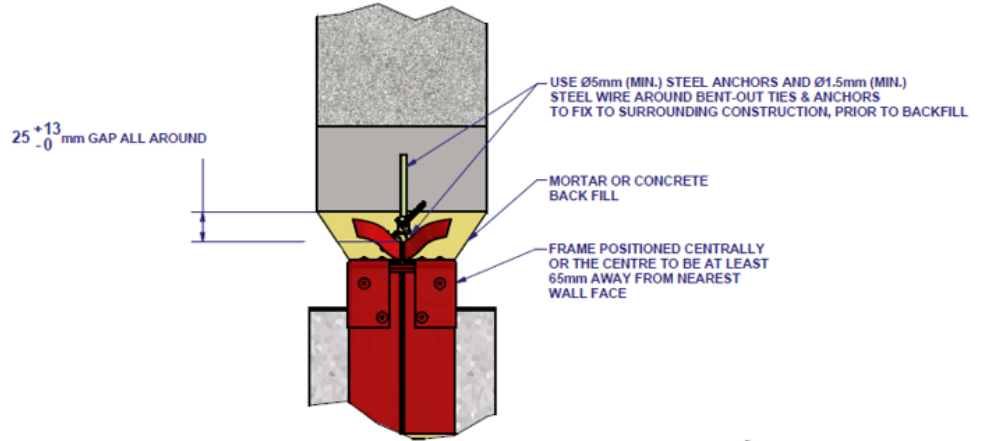

FIGURE 6

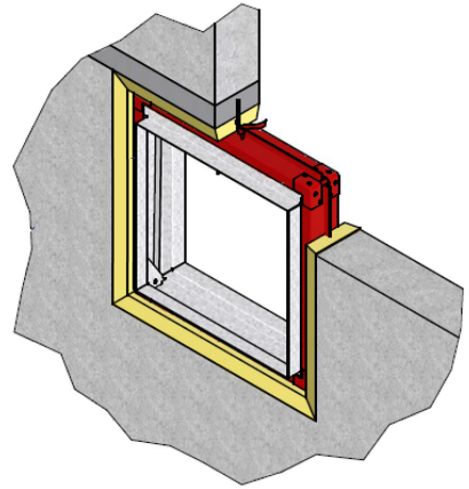

FIGURE 7

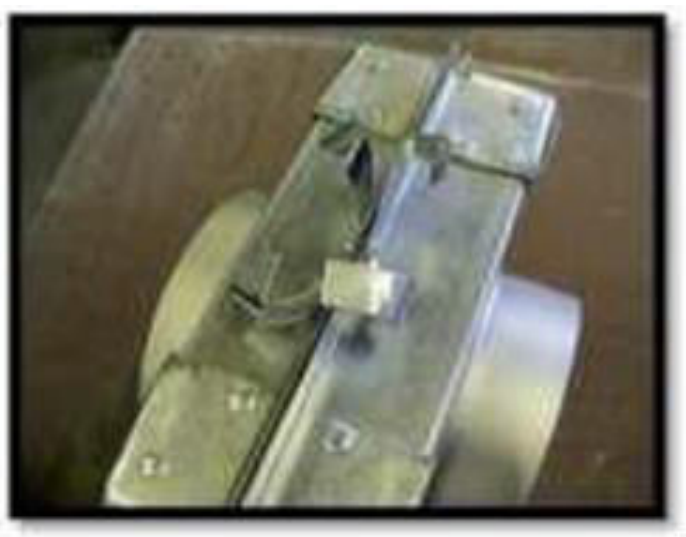

FIGURE 8



10 Angle Frame Installation into Masonry Wall – Figs 9 & 10 (Refer to FD M10)

- 10.1 Preferably, prepare opening whilst building the wall (or cut an opening if the wall already exists).
- 10.2 Determine / Measure overall damper casing size.
- 10.3 Opening size: 10mm clearance per side all around.
- 10.4 E.g. for a 750mm w x 800mm h overall extremities of the damper, the opening size should be 770 x 820mm.
- 10.5 The damper is not load-bearing and additional support for the top of the wall opening is achieved by means of a lintel or other approved method.
- 10.6 It is advisable to pre-drill the angle frame of the damper before fitting within opening. Mark nominal hole fixing positions at 150mm maximum centres 10mm in from the extremities of the angle frame flange. Drill all holes (+0.50mm clearance) to suit fixings.
- 10.7 Prepare a pair of spacing blocks, (approx. 10mm thick) from any available material (such as drywall boards). Position spacing blocks within the opening at extremities of damper and stand the damper on blocks so that damper is central in opening and provide temporary support of the damper ensuring it stays safely in position.
- 10.8 If the wall construction is aerated concrete (breeze block), Tackburn Loden Anchors 6.5mm dia x 60mm can be installed at each of the damper fixing holes. Orientate the fixings so that expansion direction follows opening sides (otherwise fracture between fixing and edge of opening may occur).
- 10.9 If the wall construction is brick or solid concrete, mark hole positions using holes in damper frame as template, then remove damper. Drill all holes to suit fixings. Reposition damper and fix. Fire Rated Steel fixings should be expanding anchor type. Min 5mm dia x Min 60mm long.

FIGURE 9

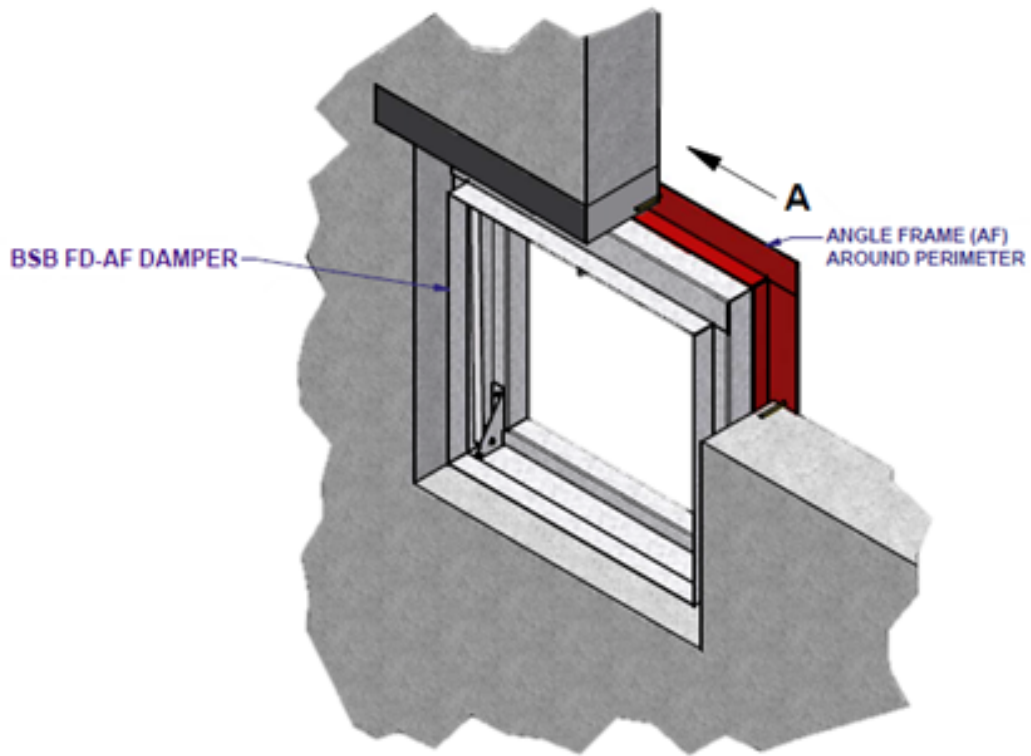
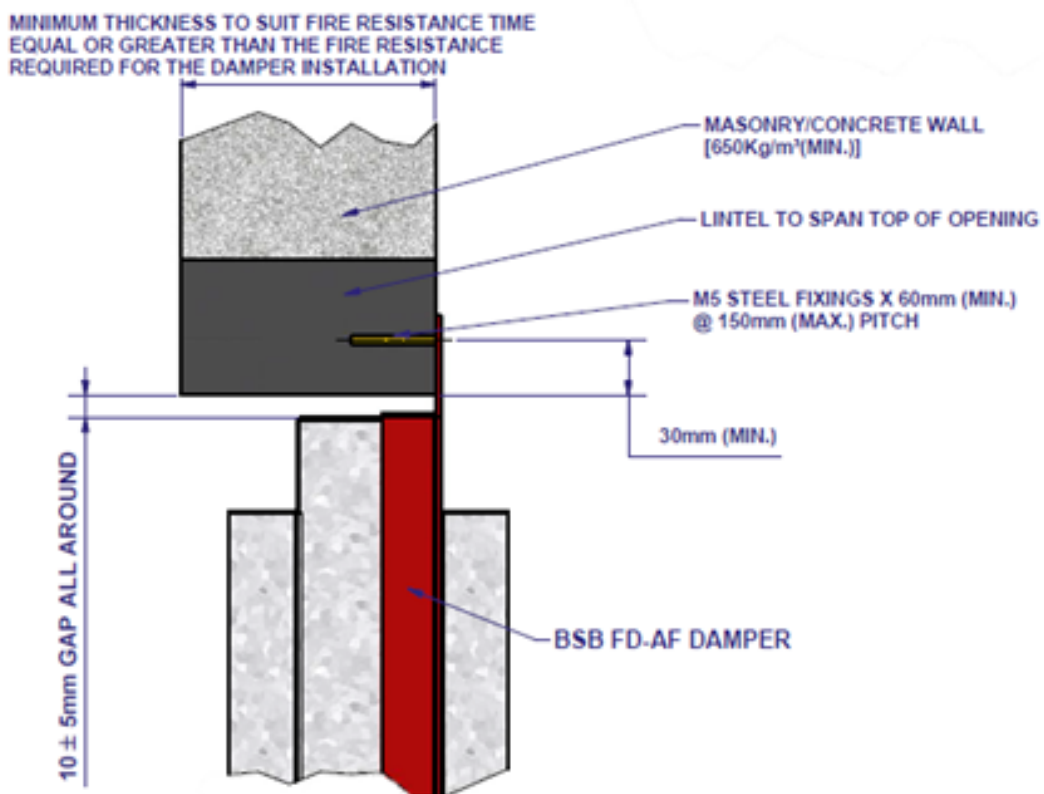

FIGURE 10



11 Angle Frame Installation into Concrete Floor – Figs 11 & 12 **(Refer to FD-M11)**

- 11.1 Preferably, prepare opening whilst building the floor (or cut an opening if the floor already exists).
- 11.2 Determine / Measure overall damper casing size
- 11.3 Opening size - 10mm clearance per side all around
- 11.4 E.g. for a 750mm w x 800mm h overall extremities of the damper, the finished size should be 770 x 820mm.
- 11.5 It is advisable to pre-drill the angle frame of the damper before fitting within opening. Mark nominal hole fixing positions at 150mm maximum centres approx. 10mm in from the extremities of the angle frame flange. Drill all (+0.50mm clearance) holes to suit fixings.
- 11.6 Position the damper centrally into the opening from above, with blade pack oriented as required.
- 11.7 If the floor construction is aerated concrete, Tackburn Loden Anchors 6.5mm dia x 60mm can be installed at each of the damper fixing holes. Orientate the fixings so that expansion direction follows opening sides (otherwise fracture between fixing and edge of opening may occur).
- 11.8 If the floor solid concrete, mark hole positions using holes in damper frame as template, then remove damper. Drill all holes to suit fixings. Reposition damper and fix. Fire Rated Steel fixings should be expanding anchor type. Min 6.5mm dia x Min 60mm long.
- 11.9 Mark hole positions on the surface of the floor, then remove damper. Drill all holes to suit fixings.
- 11.10 Fix the angle frame to the floor.
- 11.11 It is not a necessity to fill the void behind the angle frame or fit a pattress to the underside.

Connecting Ductwork

Fixings

- There must be an appropriate break-away joint between the damper and the connecting ductwork on both sides of the damper
- Typically aluminum rivets should be used

IMPORTANT: The use of TEK screws or "self-drilling" fixings are considered hazardous to those commissioning, maintaining and/or cleaning dampers

Expansion Gap

To allow expansion of the ductwork, the distance between the connecting duct and damper case should be 5 - 10mm. Failure to do so may cause the distortion to the damper case that will impact the damper operation.

FIGURE 11

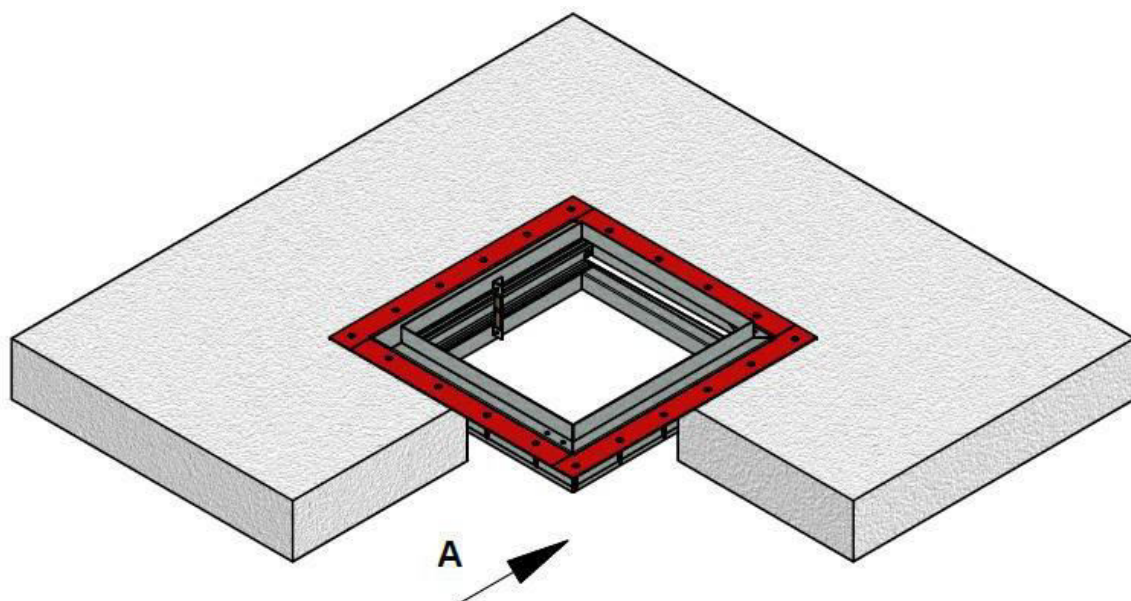
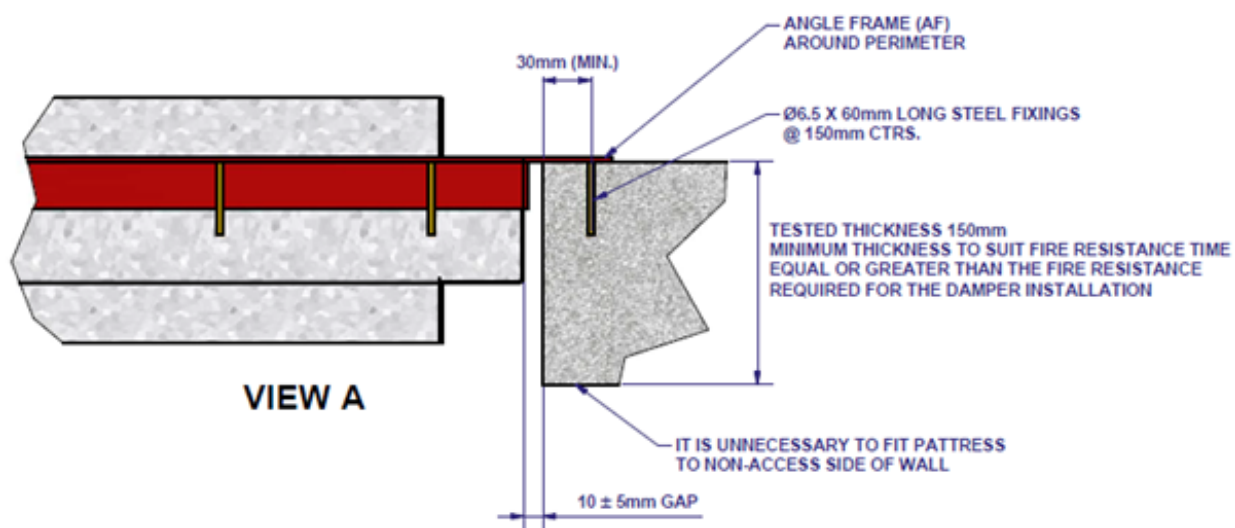

FIGURE 12



12 Flexible Curtain (Refer to FD M14)

12.1 Parts required and checks

- 12.1.1 Damper.
- 12.1.2 Two pairs of clamp plates attached to each damper.
- 12.1.3 ST4.8mm dia x19mm long safety self-tapping blunt point (qty to suit damper size). These are optional accessories at time of purchase of dampers.

12.2 Prepare and install damper into position

- 12.2.1 Remove clamp plates from the damper. The clamp plates (1pair – top/bottom and 1pair - sides). Clamp plates will be screwed in corners of the damper frame for transportation, thus aids in identification of sides and tops/bottoms. Where damper W+H are very similar, its important you note which plates are tops/ bottoms and which plates are sides.
- 12.2.2 One pair of M10 threaded drop rods are required to be suitably fixed to structure to hang vertically in a fire safe manner to fully support the weight of the damper. There is no limit on drop rod length.
- 12.2.3 To ease install, the drop rods can be joined using a coupling nut and pair of lock nuts to save having to spin the M10 nuts all the way along the length of the studding to the top cleat. i.e.:-
- 12.2.4 Upper drop rod length – The end should ~100mm below the top damper cleats.
- 12.2.5 Lower drop rod end should be ~50mm below the bottom damper cleats.
- 12.2.6 Fix drop rod structure fixings in position to allow the drop rods be positioned at a distance apart to match the pitch between the welded cleats either side of damper.
- 12.2.7 Measure required length of upper drop rods as described above, cut to length.
- 12.2.8 Fit top drop rods into structure fixings.
- 12.2.9 Position damper by passing the top cleats through the two drop rods, and fitting a pair of M10 nuts to each drop rod underneath the cleats. Ensure damper is horizontal and at required height by rotating the nuts as required.
- 12.2.10 Fully tighten structure fixings/drop rods and also each pair of cleat nuts to lock in position.
- 12.2.11 Measure required length of lower drop rods as described above, cut to length.
- 12.2.12 Pass the lower drop rods through bottom damper cleats and join to upper drop rods with coupling nut and lock nuts as view C of installation drwg
- 12.2.13 Fit a pair of M10 nuts to each lower drop rod underneath the damper bottom cleats as per view D of installation drwg. Rotate and lock the nuts so that damper weight is equally shared across all four cleats, adjusting as necessary.
- 12.2.14 Fully tighten both bottom nut pairs.
- 12.2.15 Check all structure fixings and studding nuts are tight and secure.
- 12.2.16 Test damper for operation – refer to section within IO+M.

12.3 Install FFC material Fire curtain around damper

- 12.3.1 Referring to Firefly Installation guide (www.tbafirefly.com/fire-barriers/), decide where the FFC material vertical joints will need to be positioned. Its important not to have a joint close (within 100mm) to either side of the damper frame sides. For small dampers, it may be possible that no joint is necessary between the cleats depending on the overall wall dimensions and damper position.
- 12.3.2 Fit fire curtain vertical lengths either side of damper.
- 12.3.3 Measure damper spigot position within structure and mark on the fire curtain where the cut opening is to be located, allowing for extra FFC material as necessary to attach to structure / overlap joints.
- 12.3.4 Finished opening cut size should be the damper spigot size. Any excess can be left as 'wrapping around' the spigot.
- 12.3.5 Cut opening in the FFC material to allow material to pass over damper spigot. It is advisable to cut 'a cross' diagonally from centre of spigot to the four corners only at this stage, and cut to final size once FFC material is fixed to structure /adjacent fire curtain vertical runs.
- 12.3.6 Install FFC material to structure and if applicable, overlap butt joints to adjacent FFC material run.
- 12.3.7 Cut opening/trim FFC material to spigot size with a plus 10mm tolerance for each of the spigot sides.
- 12.3.8 Locate top clamp plate in position sandwiching the FFC material. Screw to damper frame by piercing FFC material and ST4.8x19 safety self-tapping screws but leave loose until all four clamp plates are fitted.
- 12.3.9 Repeat with bottom clamp plate.
- 12.3.10 Finally, fit both side clamp plates passing through the corners holes of the top/bottom clamp plates.
- 12.3.11 Tighten all screws to securely sandwich the FFC material.
- 12.3.12 If necessary for aesthetic purposes only, trim any excess FFC material protruding near the spigot.
- 12.3.13 Wrap Penowrap around the entire length of the drop rods as per Installation drawing keeping as close to the structure fixings and cleats as possible. Secure in place using steel cable ties (250-300mm pitch).
- 12.3.14 Check damper perimeter that FFC material is intact and that no gaps/ cuts or tears exist and that the overlapping butt joints and fixing to structure remain intact. 3.15 Fit ductwork in accordance with DW145, using breakaway joints (aluminium rivets) and ensure ductwork is independently supported.

13 Instruction for testing Damper

- 13.1 Important - when manually resetting, holding open or releasing the blade pack, ensure the bottom blade remains parallel with the top of damper at all times, i.e. always hold bottom blade centrally along its length. Failure to do so, may cause the damper side springs to twist/tangle rendering the damper unusable.
- 13.2 Prior to fitting damper for first time, stand/lay damper on solid surface as per its intended installation. Ensure the blade pack is uppermost for vertical installations.
- 13.3 Standard Link
 - 13.3.1 Relieve the damper blade pressure on the fusible link by pushing bottom blade away from link with one hand and lifting the fusible link off its pair of retaining pins. Keep the fusible link safe for refitting later.
 - 13.3.2 Ensuring the blade pack path is clear, quickly remove hand holding the blade pack taking care to ensure the blades are released centrally and evenly to emulate the release of the fusible link.
 - 13.3.3 Damper blade pack closes under spring/gravity action.
 - 13.3.4 Visually check the bottom blade locks into the locking ramp notch at each side of the damper.
 - 13.3.5 Reopen the damper by pushing the bottom blade away from the locking ramps or by pulling the “ring pull(s)” depending which way round the damper is. Keeping the bottom blade parallel with the top of the case and the ring pull facing inwards, push the blade pack upwards ensuring that the blades fold in a pleated format to ensure the blades are compact when reset. It is important that the individual blades and not forcefully folded back on themselves as this may result in critical damage to the continuous interlocking hinge section where the blades join along their length.
- 13.4 Gate Latch Link
 - 13.4.1 Ensuring the blade pack path is clear, gently pull the closest gate latch lever toward you. The Fusible link swings away and is retained on the other side of the gate latch bracket. (Note: for dampers above 150mm high or dia, the gate latch function is from either side. Below this damper size, gate latch function only operates from the non ramp side).
 - 13.4.2 Damper blade pack closes under spring/gravity action.
 - 13.4.3 Visually check the bottom blade locks into the locking ramp notch at each side of the damper.
 - 13.4.4 Reopen the damper by pushing the bottom blade away from the locking ramps or pulling the “ring pull(s)” depending which way round the damper is. Push blade pack towards and into top hat of the damper and refit the fusible link pin into its retaining slot of the fusible link retainer.

14 Routine Inspection, Testing and Maintenance

- 14.1 Refer to Health and safety procedure (section 1)
- 14.2 In accordance with BS 9999 Annex W.1, inspection should be undertaken annually. Local regulations/conditions may override this with periodic Inspection being carried out more frequently where corrosive or dirty conditions prevail. The maintenance log should be reviewed at each inspection and the frequency adjusted as required dependent upon findings. (BSB recommend a maximum of 1 year between inspections and to start more frequently initially and reduce frequencies only if conditions are proven to allow).
- 14.3 Remove access door to reveal damper's internal elements.
- 14.4 Visually inspect the internal damper elements for signs of corrosion, obstruction or accumulated dirt/dust.
- 14.5 If there are any obstructions or if the damper's blades, side springs, case side seals are dirty, they need to be cleaned.
- 14.6 Use a soft cloth with a light application of light lubricant. (Connect Duck Oil recommended).
- 14.7 There should be no more than a thin film of lubricant applied. Remove all excess lubricant. It is particularly important as excess oil will tend to collect dirt and dust which will have a negative effect on dampers remaining clean.
- 14.8 Replace access doors, ensuring the damper is left open.
- 14.9 Record all work that has been undertaken in the maintenance log.
- 14.10 It is important to record, and review maintenance frequency based on inspections and test history.

Figure 13

(The table below, gives guidance on threaded drop rod sizing for damper weight and fire rating)

Drop-rod load bearing specification for Fire Rating:			
Drop-rod size	Max load per pair of studs (kg)		
	E60	E120	E240
M10	159	106	63

15 Fault finding

Symptom	Fault	Action
Damper does not close properly when drop tested	Foreign object impeding blades	Remove item
	Buildup of dirt / dust / corrosion impeding blades	Remove / clean case & blades as required (see section 11)
	Springs twisted / kinked	Springs will require replacement. Refer to BSB technical sales office.
Gate Latch link not retained when releasing blade pack via the release lever.	Release lever bent inwards allowing fusible link to come into contact when blades are released	Bend lever by hand to 90° with damper case. See figure 14 below
Damper closed when open state is expected	Fusible link released Air Temperature of the link has been exceeded.	Replace link. Refer to BSB technical sales office.
	Fusible link missing or not fitted correctly	Fit link

Figure 15

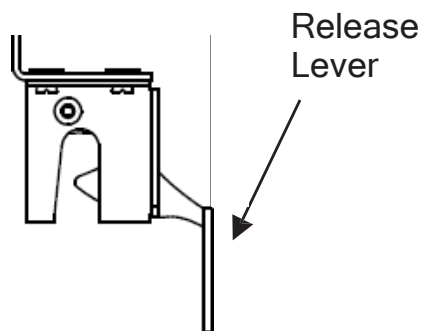

Installation Check List

DAMPER REFERENCE NO.:	DAMPER LOCATION:	
DAMPER SIZE:		
WIDTH	HEIGHT	
WALL/FLOOR APERTURE SIZE ('OPENING SIZE')		
WIDTH	HEIGHT	
DAMPER INSTALLED BY:		
(Print name)		
Signature:	Company:	Date:
FINAL INSPECTION BY:		
(Print name)		
Signature:	Company:	Date:



A brand of
MAICO

This document is available to download from the BSB website.
This document is subject to change without notice.

BSB Engineering Services Ltd
Tel +44 (0)1795 422609

Email: enquiries@bsb-dampers.co.uk website: www.bsb-dampers.co.uk

V1 March 2022

FD Series

Installation, Operation and Maintenance Instructions



Other Air, Fire and Smoke Control Products in the BSB Range:



For full details of the complete BSB Product Range, please refer to our individual product brochures, sales office or website.



A brand of
MAICO

BSB Engineering Services Limited

Unit 56, Trinity Trade Centre, Mill Way, Sittingbourne, Kent ME10 2PD, UK • Tel: +44 (0)1795 422609

For purchase orders and order related enquiries, please email: orders@bsb-dampers.co.uk

For pricing, technical and general enquiries, please email: enquiries@bsb-dampers.co.uk

Website: www.bsb-dampers.co.uk • A member of the Maico group

BSB Engineering Services Ltd. reserves the right to modify or withdraw any specification without prior notice that may result from continuous product development. The information contained within this brochure is correct at the time of going to press.



Assessed to ISO 9001:2015
Certificate No. 1464

