



Electrical Door Drive - Chain Drive

HCV Door Drive 24/48VDC

318061



FEATURES:

- For all doors
- Compact and elegant design
- Built-in electronic overload protection
- Power supply 24/48VDC
- 2 wire line monitoring
- Up to 500N force at chain entrance point
- 600 mm chain length
- Soft Close function (reduced closing speed)
- 2.5 m Silicone cable
- Housing made of anodized aluminium
- Tested according to EN12101-2

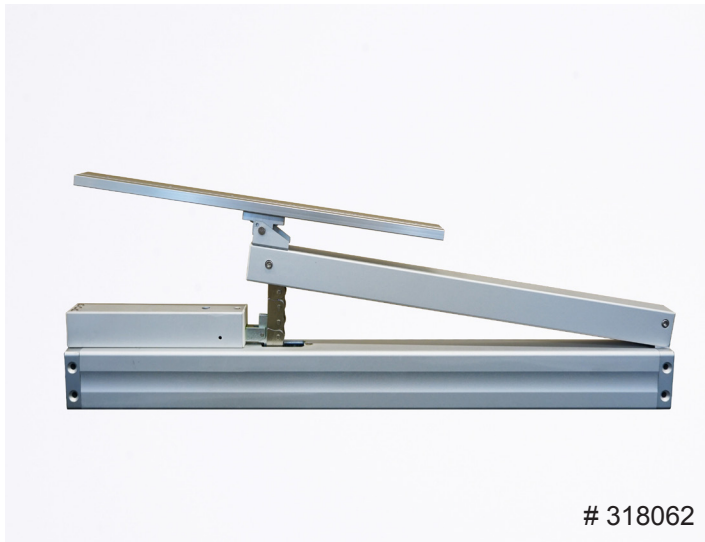

318062

DOOR DRIVE WITH SLIDER

The door drive is also available in an edition, where the moving arm is fixed to a slider, allowing you to keep the door/window in a certain position.

The slider is mounted on the doorplate or the window frame. This enables the door/window to remain unaffected by wind and ensures the door/window stays in the same position as the arm. When the door drive returns to the closed position, it will also bring the door/window back.

The door drives can be mounted in synchro, for example one at the top and one at the bottom of the door/window.

Electrical Door Drive - HCV 24/48VDC

Model	Power supply	Pushing/pulling force (N)	Opening angle	Locking pressure	Protection	Temperature	Speed (mm/sec.)		Size (mm) (LxWxH)
Door Drive							Natural	Smoke & Heat (High Speed)	
HCV 500/600mm	24VDC / 1.4A 48VDC / 0.7A	500 / 500	90°	2000 N	IP 32	-25° C - +75° C	7	10	587 x 82 x 41

Dimensions

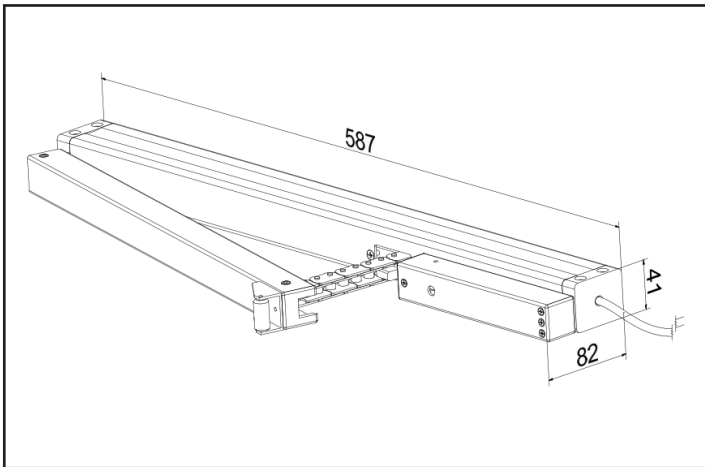

Bracket set for Inwards opening

item no.390061

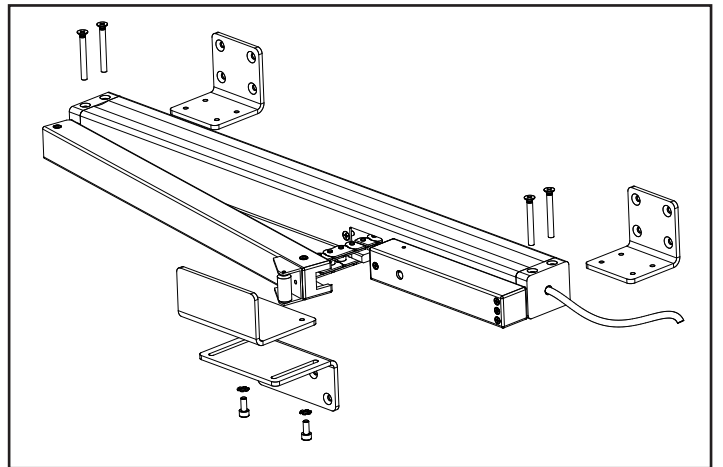

Outwards opening

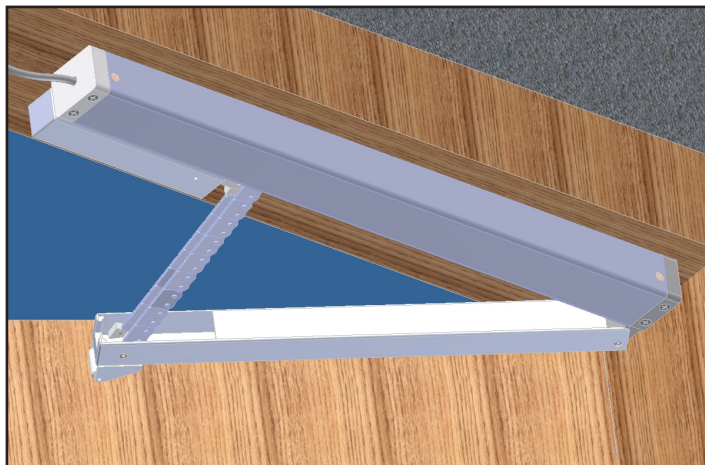

Inwards opening

