



CLASSIC SAX

Installation & Maintenance

Installation Instructions

1.0 Range

- 1.1 All versions have delay action, slow moving shutters.
- 1.2 "A" models can be wired for INTAKE ONLY, EXTRACT ONLY or EXTRACT OR INTAKE (with a double pole three position switch not supplied). Refer to wiring diagrams for connection options.
- 1.3 "AR" and "ARB" models must be installed with the controller included in the box. Refer to wiring diagrams for connection options. These models have several modes of operation via the supplied controller; Extract (5 speeds), Intake (5 speeds) and Fan stopped with the shutters remaining open.

2.0 General

- 2.1 It is important these Installation and Maintenance Instructions are fully adhered to.
- 2.2 Full details of the unit supplied are shown on the product nameplate. If in doubt about any detail contact Elta Ltd or its agents for clarification.
- 2.3 All electrical installation must be carried out by suitably qualified and competent personnel in accordance with all current statutory requirements.
- 2.4 These instructions cover only the Elta Ltd product and do not include the supply or installation of any safety equipment that may be required e.g. adequate guarding or protection from rotating parts and proper electrical isolation.
- 2.5 Any declarations made by Elta Ltd about product installation and safety, are dependant on the fan equipment being used within installations which themselves meet the requirements of the relevant Standards and Directives of your region.
- 2.6 The fan is designed for use in an ambient temperature of up to +40°C and up to 95% relative humidity. The fan is not suitable for corrosive or explosive atmospheres.
- 2.7 The installer should provide easy access to the fan to facilitate future maintenance. The installer should ensure the fan is adequately supported.
- 2.8 This product is not intended for use by persons (including children) with reduced physical, sensory or mental capabilities, or lack of experience and knowledge, unless they have been given supervision or instruction concerning use of the product by a person responsible for their safety.
- 2.9 Children should be supervised to ensure that they do not play with the product.
- 2.10 At end-of-life, the unit must be disposed of in an environmentally friendly manner by suitably qualified and competent personnel in accordance with the requirements of applicable Standards and Directive

3.0 General Installation

WARNING – The fan must be isolated from the power supply during installation and maintenance. The fan is double insulated and does not require an earth connection.

- 3.1 Upon receipt, the fan equipment should be visually inspected to check for any damage. Ensure that the impeller is free to rotate.
- 3.2 If there are any queries concerning the fan equipment, Elta Ltd should be contacted prior to the installation.
- 3.3 The fan is designed for Window, Wall or In-wall mounting (depending on model) in the desired position to suit the application.
- 3.4 The fan should be installed at a minimum height of 2.3 m.
- 3.5 Check the details on the motor rating plate to ensure that the correct power supply (voltage, frequency and phase) is available. An incorrect power supply will lead to permanent damage to the fan motor.
- 3.6 Refer to the appropriate wiring diagram.
- 3.7 Means for electrical disconnection must be incorporated in the wiring installation in accordance with the relevant wiring and electrical regulations.
- 3.8 Precaution must be taken to locate the exhaust discharge terminal so as to avoid the backflow of gases into the room from the open flue of gas or other fuel burning appliances.

4.0 Window Mounting Installation

- 4.1 Cut a hole as indicated in FIG 1.
- 4.2 Remove the screws (L) from the front grille (A) to release it from the body of the fan unit (B). (FIG 2)
- 4.3 Separate the fan body (B) from the inner clamp plate (C). (FIG 3)
- 4.4 Separate the inner clamp plate (C) from the outer clamp plate (D). Note that the outer clamp plate is shown in the pictures without rear protective grille. It is NOT necessary to divide them. (FIG 4)
- 4.5 Place the outer clamp plate (D) and the rear grille in the hole made in the glass or partition from the rear and fix it in place using the tabs (E) to hold in place. (FIG 5)
- 4.6 Place the inner clamp plate (C) on the inside of the glass and screw it to the outer clamp plate (D) using four 60 mm bolts supplied (F). (FIG 6)
- 4.7 Place the body of the fan unit (B) in position and screw it to the inner clamp plate C using four 30 mm bolts supplied (G). (FIG 7)
- 4.8 Remove the screws (J) from the connection box cover (I). (FIG 8)
- 4.9 Remove the cover from the cable entry (H) and carefully cut a suitable hole in it. Thread the connection cable through the hole until it reaches the connection box cover (I) connect the cable to the terminal strip as shown in the corresponding wiring diagram. (FIG 9)
- 4.10 Position the covers on the cable entry point (H) and the connection box (I) and replace the screws (J). (FIG 10)
- 4.11 Replace the front grille (A) and fix it in place using the 4 screws (L) previously removed. (FIG 11)

Installation Instructions

5.0 Wall Mounting Installation

- 5.1 Cut a hole as indicated in FIG 1.
- 5.2 Remove the screws (L) from the front grille (A) to release it from the body of the fan unit (B) (FIG 2)
- 5.3 Separate the fan body (B) from the inner clamp plate (C). (FIG 3)
- 5.4 Separate the inner clamp plate (C) from the outer clamp plate (D). Note that the outer clamp plate is shown in the pictures without rear protective grille. It is NOT necessary to divide them. (FIG 4)
- 5.5 Screw the 35 cm long rods (A') into the outer clamp plate (D). (FIG 12)
- 5.6 Place the outer clamp plate (D) with the rods (A') in the outside part of the hole in the wall, ensuring that the length of the rods protruding from the wall is approximately 20 mm to prevent interference when installing the body of the fan (B). Place the inner clamp plate (C) on the inside of the wall matching up the four (4) interior housings with the rods and then use the nuts to fasten the two plates together. (FIG 13)
- 5.7 Place the body of the fan unit (B) in position and screw it to the inner clamp plate (C) using four 30 mm bolts supplied (G). (FIG 7)
- 5.8 Remove the screws (J) from the connection box cover (I). (FIG 8)
- 5.9 Remove the cover from the cable entry (H) and carefully cut a suitable hole in it. Thread the connection cable through the hole until it reaches the connection box cover (I) connect the cable to the terminal strip (K) as shown in the corresponding wiring diagram. (FIG 9)
- 5.10 Position the covers on the cable entry point (H) and the connection box (I) and replace the screws (J). (FIG 10)
- 5.11 Replace the front grille (A) and fix it in place using the 4 screws (L) previously removed. (FIG 11)

6.0 In Wall Mounting Installation

- 6.1 Make a square hole in the wall: 365 mm by 365 mm for 23/9's and 440 mm by 440mm for 30/12's.
- 6.2 Place the Interior part of the kit (Y) with the circular hole at the top and fix it to wall with plaster, cement, etc., protecting the threaded fixing points in the sides of box (These are used to fit the trim surround). NOTE: the interior part is the smaller one).
- 6.3 Loosen the screws (L) from the front grille (A) to free it from the body of the fan (B)
- 6.4 Separate the inner clamp plate (C) from the body of the fan by a turning movement, turn the inner ring by 180°, the fan support (O) has to be placed in the lower part not to interfere with the assembly.
- 6.5 Fit the inner clamp plate (C) to the KIT body (Y) using four V1 bolts
- 6.6 Wire the fan as indicated in the fan instructions leaflet, following steps 5.8, 5.9 and 5.10 above
- 6.7 Place the fan body (B) and screw it to the inner clamp plate (C) using four V1 bolts
- 6.8 Place the front grille (A) and secure it with the screws (L)
- 6.9 Fit the interior trim surround (X) and screw it in place using four V2 bolts provided
- 6.10 Place the Exterior part of the kit (Z) with the circular hole at the top and fix it to the wall with plaster, cement, etc., protecting the threaded fixing points in the sides of the kit. (These are used to fit the trim surround). NOTE: the exterior part is the larger one.
- 6.11 Dismantle the outer grille (W) from the outer clamp plate loosening the 4 screws.
- 6.12 The outer clamp plate piece is not used for the wall Built-In Kit.
- 6.13 Fix the outer grille (W) to the supports of the exterior part of the kit (Z) using the four V3 bolts.
- 6.14 Fix the exterior trim surround (X) using four V2 bolts

7.0 Start Up

- 7.1 Before power is supplied to the unit, check that the wiring is correct as per the fan connection diagram.
- 7.2 At initial start-up, check that impeller rotation and airflow direction is correct.
- 7.3 Check that the motor amperage draw does not exceed the nameplate rating.

8.0 Fan Maintenance

- 8.1 Inspection of the fan at least once every 12 months is recommended to ensure that the motor, fan blades, and supporting guards, are clean. Any build up of dust and deposits on the blades or guards should be removed using a non-abrasive cleaner.
- 8.2 All fastenings should be checked for tightness. In addition, all rotating items should be checked.
- 8.3 Bearings are of the 'sealed for life' type and will not need a detailed inspection.

CLASSIC SAX

Installation Instructions

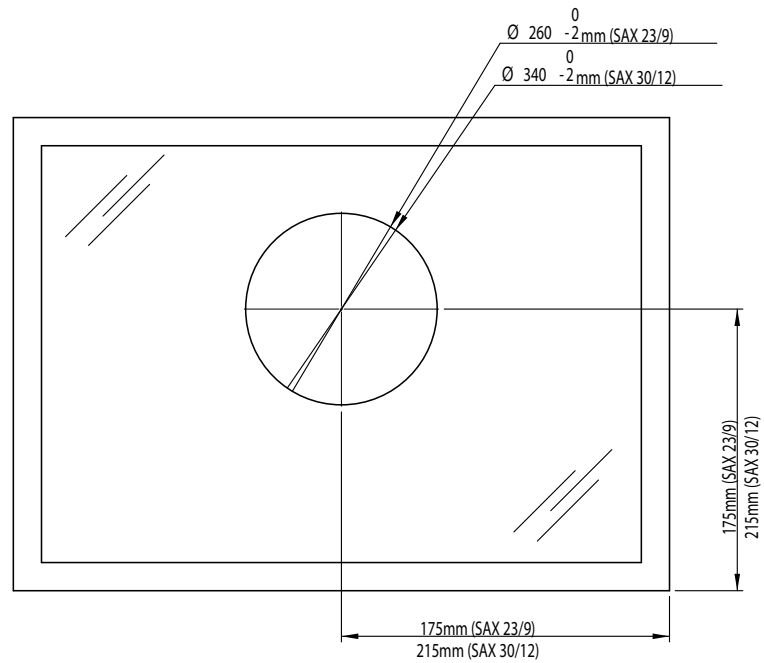
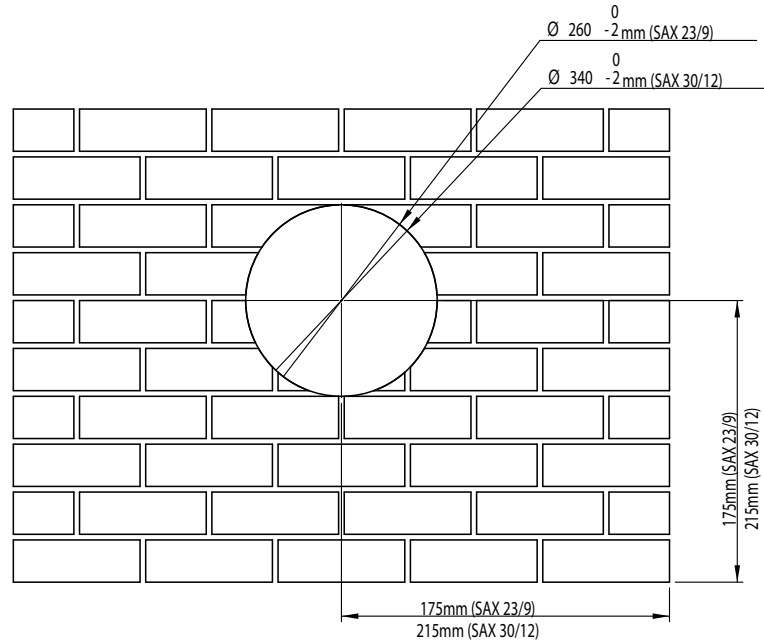

CLASSIC SAX

Installation Instructions

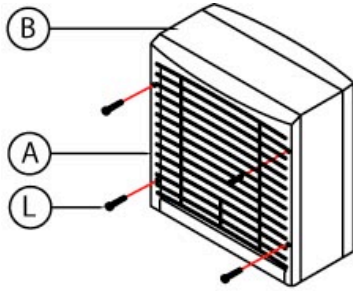

FIG 2

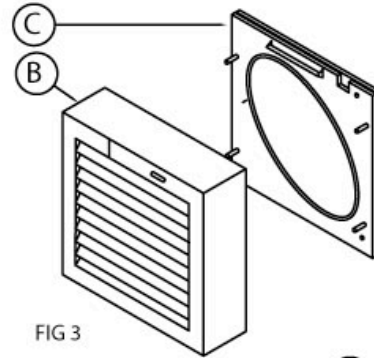

FIG 3

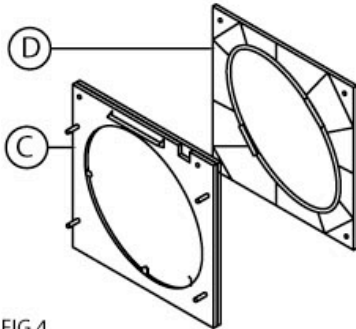

FIG 4

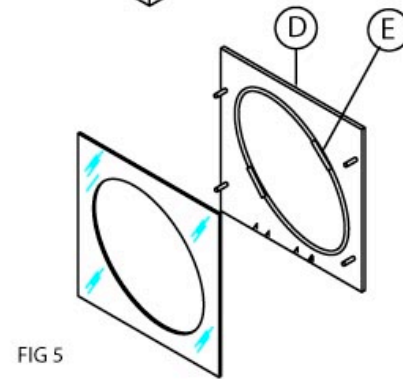

FIG 5

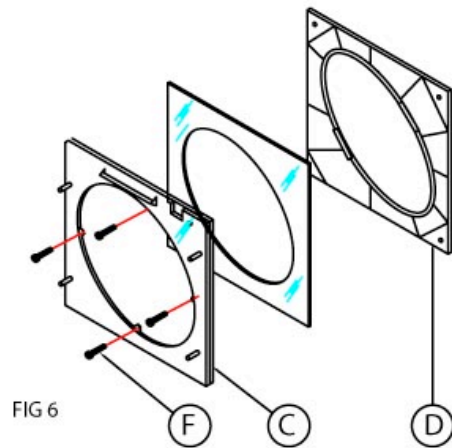

FIG 6

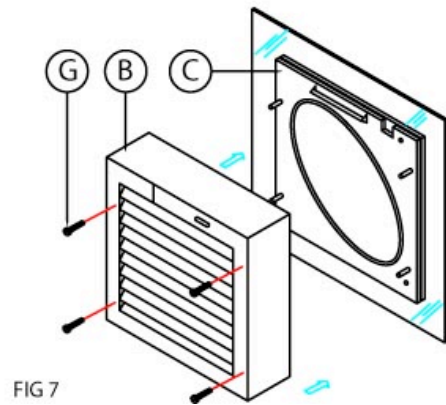
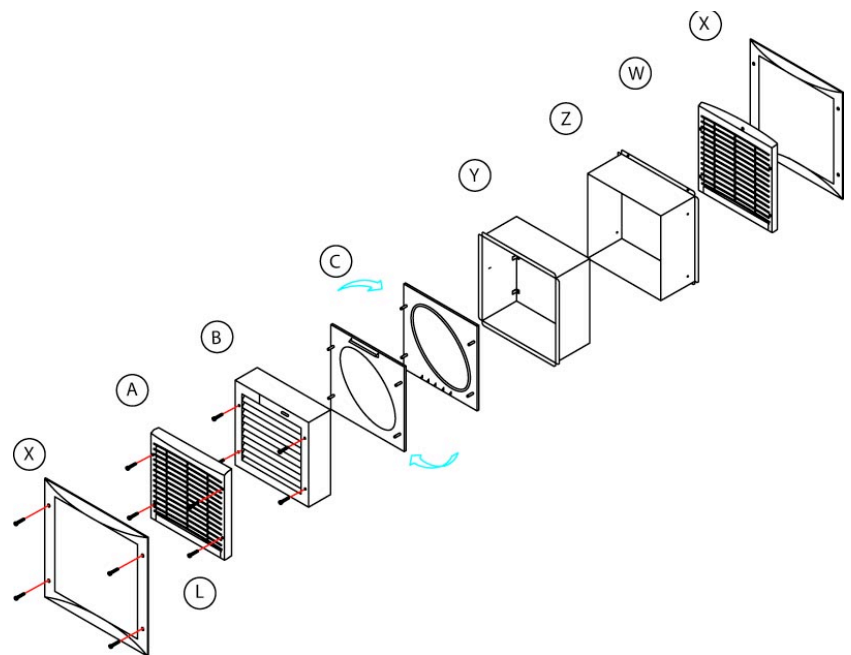
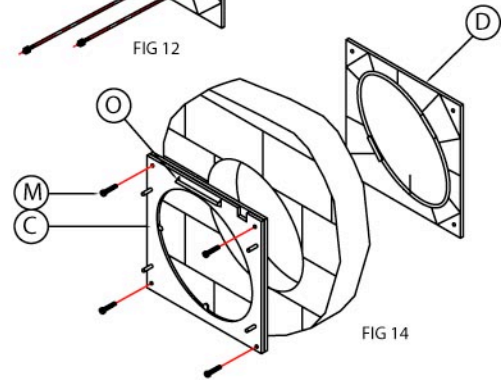
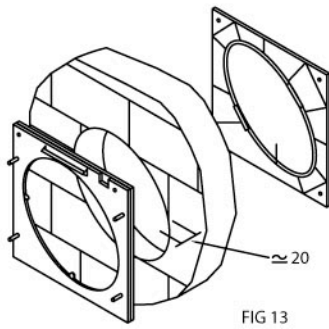
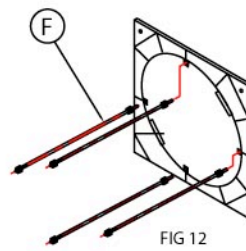
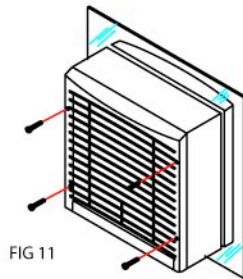
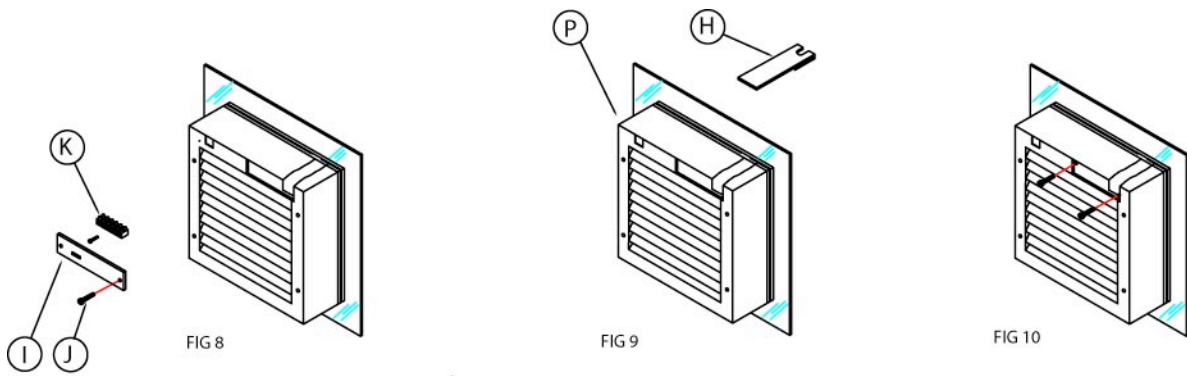

FIG 7

CLASSIC SAX

Installation Instructions



Telescopic Kit
Comprises
Fan
Interior Metal Sleeve
Exterior Metal Sleeve
2 Trim Surrounds
Fasteners
(V1) 8 x M5 x 30 Bolts
(V2) 8 x M4 x 14 Bolts
(V3) 4 x M3 x 16 Bolts

CLASSIC SAX



Wiring Diagrams

Please use the table(s) below to match up the product code and the wiring diagram number.

Single Phase 200V - 240V / 50Hz

Page No.	Product Code	Wiring Diagram No.
8	SAX23/9A	152-512
8	SAX23/9AR	152-512
8	SAX23/9ARB	152-512
8	SAX/12A	152-512
8	SAX/12AR	152-512
8	SAX/12ARB	152-512

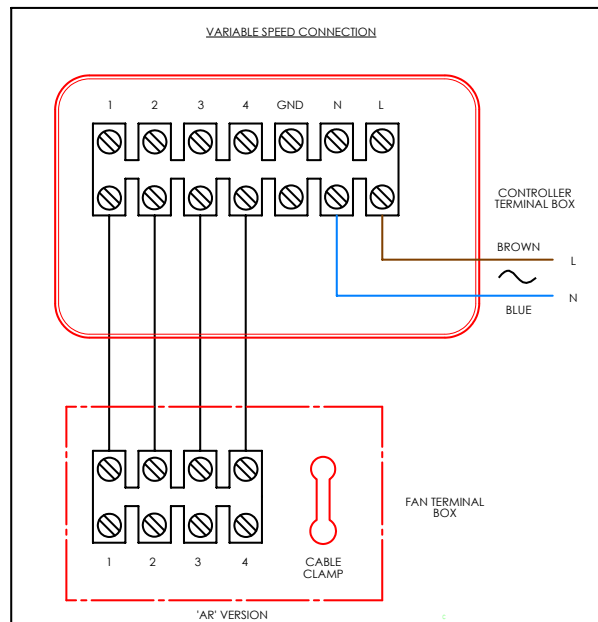
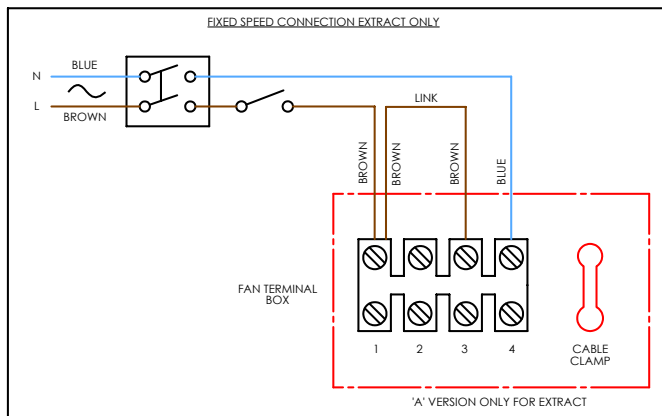
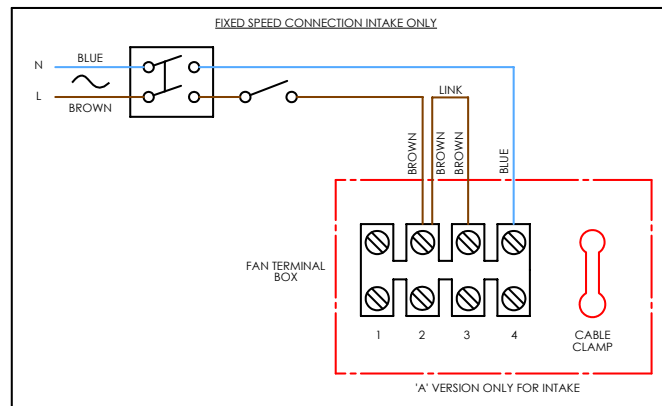

All wiring and control equipment must comply to the latest IEE regulations, in particular part 552-01-02/03.
 MK-152-512 Issue B: 05.05.2022
 Check the individual product accessories table for fan controller compatibility.

CLASSIC SAX

Notes

ELTA

Tel **+44 (0) 1384 275800**
Email **info@eltauk.com**
eltauk.com

535-IOM0079 Issue D



BS EN ISO 9001:2015 FM 556465



A MEMBER OF  ELTA GROUP